

Plan Notes

1. Series Number: LA04-04.502E.WB-W17N
2. Grate: #2542
 - Material: Ductile Iron Per ASTM A536 Grade 80-55-06 (Uncoated)
 - Load Rating: 620 PSI (Modified AASHTO M-306 Test Method)
 - Made in U.S.A.
3. Concrete Thickness and Reinforcement per Structural Engineer's Specification for the Application

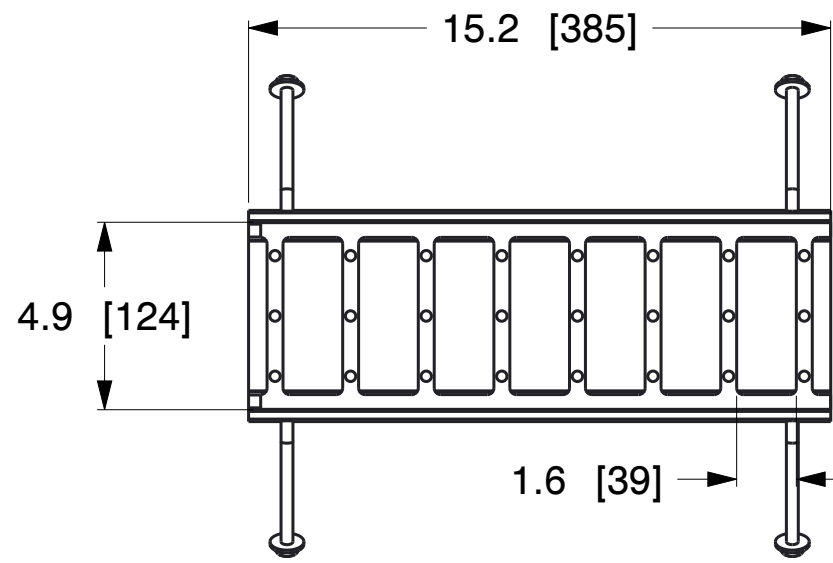

GRATE TOP VIEW
(ROTATED 90°)

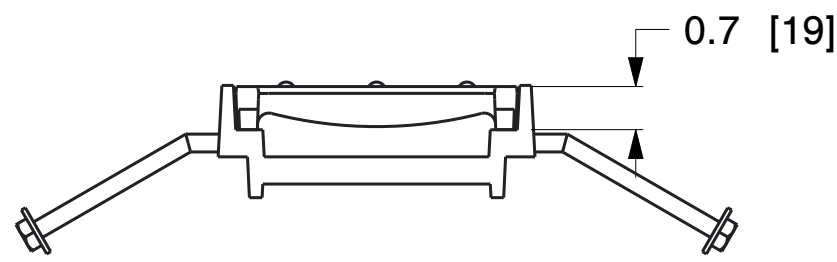

GRATE END VIEW

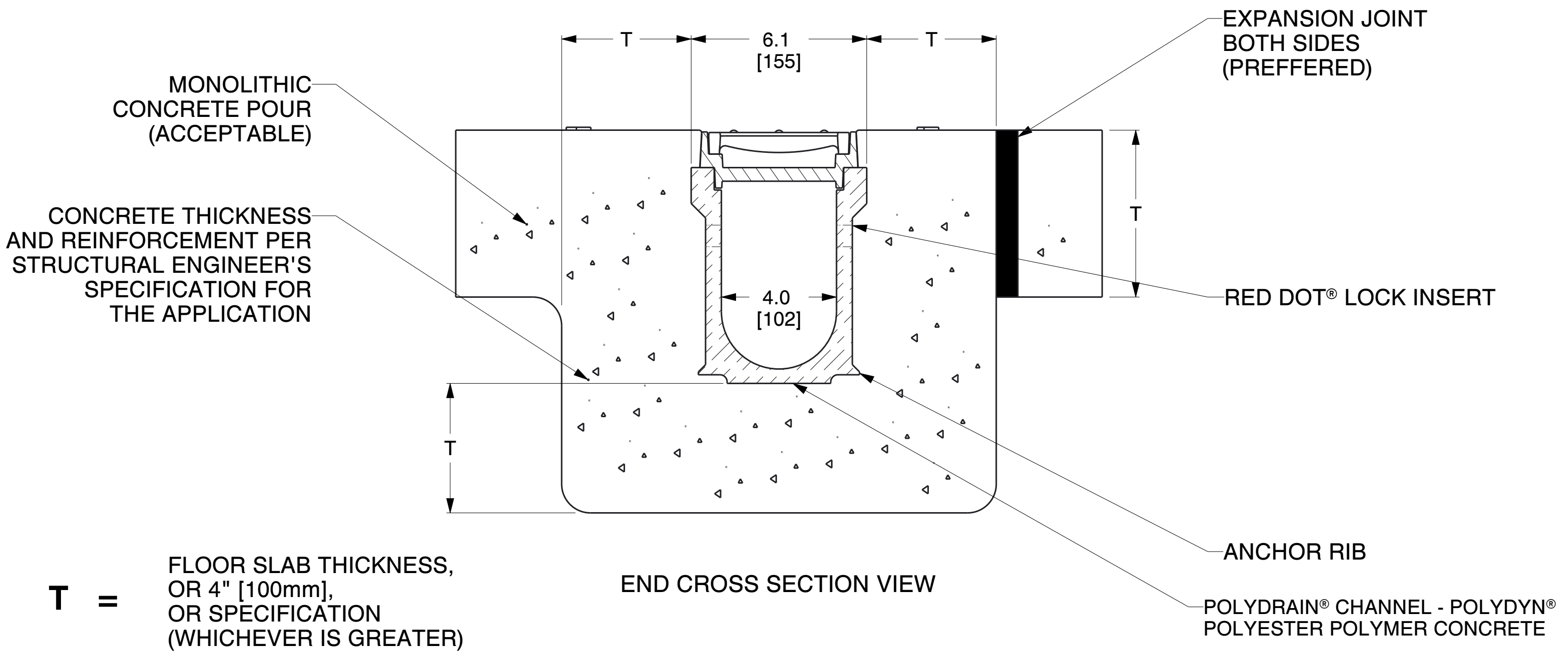

T = FLOOR SLAB THICKNESS,
OR 4" [100mm],
OR SPECIFICATION
(WHICHEVER IS GREATER)

END CROSS SECTION VIEW

Copyright © 2018 ABT, Inc.

ABT, INC.

P.O. BOX 837, 259 MURDOCK ROAD
TROUTMAN, NC 28166
(704) 528-9806

**PolyDrain - 4" [100 mm] ID - PolyDrain System
High Intake Slotted**

SERIES: **LA04-04.502E.WB-W17N**

UNITS: INCH [MM]

Proprietary rights of ABT, Inc. are included in the information disclosed herein. The recipient, by accepting this document, agrees that neither this document nor the information disclosed herein nor any part thereof shall be copied, reproduced or transferred to others for manufacturing or for any other purpose except as specifically authorized in writing by ABT, Inc.

DISCLAIMER: The specifications of the actual materials provided by ABT may vary from the specifications of the materials described herein in immaterial respects. ABT Inc. reserves the right to make changes in grate design or materials. Please call ABT for the most up-to-date information available. The customer and the customer's architects, engineers, consultants and other professionals are completely responsible for the selection, installation, and maintenance of any product purchased from ABT, and EXCEPT AS EXPRESSLY PROVIDED IN ABT'S STANDARD WARRANTIES, ABT MAKES NO WARRANTY, EXPRESS OR IMPLIED, AS TO THE SUITABILITY, DESIGN, MERCHANTABILITY, OR FITNESS OF THE PRODUCT FOR CUSTOMER'S APPLICATION. Copies of ABT's standard warranties are available upon request.

PolyDrain – 2542

4" (100 mm) ID Precast Trench Drain with Uncoated High Intake Slotted Grate

STANDARD SPECIFICATION**System ID#: LA04-04.502E.WB-W17N**

Manufactured by ABT, Inc., 259 Murdock Road, Troutman, NC - (800)438-6057.

www.abtdrains.com**System Components :**

Precast Trench Drain : The precast trench channel shall be manufactured using aggregate and Polyester polymer concrete with the following material properties when tested:

Property	Test Method	Value
Compressive Strength	ASTM C579	14,000 psi Minimum
Bending Strength	ASTM C580	4,000 psi Minimum
Tensile Strength	ASTM C307	2,000 psi Minimum
Moisture Absorption	ASTM D570	0.1% Maximum
Chemical Resistance	ASTM C267	Pass
Freeze/Thaw w/o weight loss	ASTM C666	1,600 Number of Cycles Minimum
Resistance to Fungi	ASTM G21	Zero (0) Rating Mold Growth
UL/ULC Listed- Flame Spread	UL-723	Class A

The trench consisting of 39.19" (1 meter) or 19.56" (1/2 meter) channels with nominal 6" (155mm) outside width, 4" (100mm) inside width. Pre-sloped channels shall have a standard slope of 0.6% with round bottom. Non-sloping channels must have written approval by engineer prior to installation. Channels shall have tongue and groove joints sealed with PolySeal Joint Sealer, or equal, sealant suitable for the application. Grate lock down slots shall have polyethylene vibration dampening inserts. All channels must have full length anchoring ribs for a positive mechanical lock with the surrounding concrete.

Sidewall Extensions : Sidewall extensions for channels may be used for hydraulic performance or to maintain the standard slope of 0.6% in greater trench run lengths. Sidewall extensions shall be composed of similar material and thickness as the channels and shall have tongue and groove joints.

Grating - 2542 : Uncoated grates. Grates to have a 0.27 Ft² /LFt (0.082 m²/Lm) open area. Grates shall pass a proof load of 620 psi (Modified AASHTO M-306 Test Method) applied to a 9" long x 3" wide load contact area. Covers are manufactured integral with their frame and are not removable. as shown in the Detail Sheet.

Frames - W17N : Grates are supported by independently anchored frames installed in the grate seat of the channels.

Buy America Requirement : All metal components shall be made in U.S.A. and shall conform to the FHWA's "Buy America" policy 23 CFR 635.410(b) and Federal Acquisitions Regulations (FAR) 52.225 "Buy American Act" if Federal Aid finances apply.

Quality Assurance :

Submittals : A Certificate of Compliance in conformance with the provisions of these Standard Specifications shall be furnished to the Engineer. Grates shall be tested by an independent third-party.

Post Construction Inspection : Formwork is to be fully removed, without exception, to allow for inspection and if needed repair of any voids and or concrete consolidation issues below the frame, trench walls and invert. Grate and grate retainer inspection shall be performed to ensure that all grates and retainers are installed and are properly seated in place.



World Leader in Water Management Solutions