

# PolyDrain<sup>fi</sup>

Pre-Engineered Surface Drainage Installation Manual



## PolyDrain Installation Guide

**ABT, INC.**

P.O. Box 837 ■ 259 Murdock Road ■ Troutman, NC 28166

Tel (704) 528-9806 ■ Fax (704) 528-5478

Toll free in the U.S., Canada, and Mexico (800) 438-6057 ■ [www.abtdrains.com](http://www.abtdrains.com)

Sealants .....	2	Grating Installation Prior to Concreting .....	8
Tools for Installation .....	3	Alternate to Grating Installation Prior to Concreting .....	8
Safety and Installation Tips .....	3	Channel Installation (General) .....	9
Excavation .....	4	Channel Installation with PolyClip .....	9
System Layout .....	4	Channel Installation using PolyWing Hangers .....	11
Cutting Polymer Concrete and Forming Miter Joints .....	5	Channel Installation by Suspended Method ...	12
Piping Connections and Preformed Cutout Removal .....	5	Channel Installation with Bedding Slurry .....	12
Catch Basin Installation .....	6	Polywall Sidewall Extension Installation .....	13
Horizontal and Vertical Outlet End Plates and Closed End Plates .....	7	Concreting .....	15
Installation of Channel Across Expansion/Contraction Joints in Floor Slab ...	7	Cleanup and Final Grate Installation .....	16

## Sealants

When PolyDrain channels are meant only to handle rain water surface drainage, joint sealing may not be necessary. However, when the handling of corrosives or chemical solutions is a concern, sealants must be used. Moreover, it is essential that the type sealant used is appropriate for the application in order that fluid seepage be avoided.

ABT produces three such sealant products under the name, PolySeal. Each has particular qualities that make it best for certain drainage applications.

**(NOTE: Roughen mating surfaces of PolyDrain channels with a wire brush or similar tool and clean with acetone prior to application of the sealant in order to assure proper adhesion.)**

**PolySeal 1** - This product is a flexible polyurethane sealant, ideal for dirty water (noncorrosive) applications. PolySeal 1 maintains flexibility after drying. It comes in a standard size caulking tube, immediately ready for application to PolyDrain channels.

**PolySeal 2** -This two-part epoxy sealant comes in twin tubes and is applied using a special caulking gun and mixing nozzle. It is intended for limited corrosive application with either regular PotyDyn or PolyChampion channels. It maintains flexibility after curing.

**PolySeal 3** - This product is a two-part vinyl ester compound intended for highly corrosive applications or with channel fabrications (e.g. miter joint) when a rigid set is required in conjunction with our PolyChampion channels.

Consult ABT sales support for recommendations concerning your installation.



## Safety and Installation Tips

■ **IMPORTANT - READ ALL INSTALLATION NOTES** pertaining to your particular type of installation **BEFORE** starting the job. Avoid costly mistakes!

■ If system is to carry corrosive solutions, refer to the "Sealants" section before installation or contact your PolyDrain dealer for more information.

■ The trench excavation must allow for the thickness and reinforcement specified by the designer or structural engineer.

■ Do not design slab where channels are the expansion joint.

■ If concrete shrinks away from system, channel strength will be compromised.

■ Lay out PolyDrain channels (in order of installation) alongside trench excavation prior to installation. Consult construction plans or shop drawings for correct numerical sequence.

■ Make pipe connections and set catch basins prior to channel installation.

■ Begin installation at outlet or discharge end of each run and work backwards (upstream). Each side of every channel has an arrow indicating the direction of flow.

■ Prior to concreting, place 4 15/16" wide plywood strips or grates covered with plastic along with spacers between the grate and grate lip. This helps to maintain channel alignment and prevents concrete from spilling into the channel.

■ All PolyDrain **frame & grate** systems are designed to fit on top of the PolyDrain channel. The additional height (1.2") should be taken into account when setting the channels to insure the desired finished slab elevation will be equal to the top of the overlay frame or grating.

NOTE: If 600 series catch basins are used, always allow 1.2" for frame and grate.

■ Good concrete practices should be followed to control concrete shrinkage which can break channels and other related components. Intimate contact from the encapsulation concrete is also required for PolyDrain channels and catch basins to obtain full load capacity. Use good concrete practices to minimize and control slab expansion movement and forces from breaking PolyDrain components. Cold joints adjacent to PolyDrain components should be avoided or controlled.

The encapsulation concrete's strength, thickness, and reinforcement should be that recommended by the customer's structural engineer for the intended application.

## Tools

Some or all of the following tools may be required for your particular installation:

- 12" length of 2 x 4's - lengths will vary depending on application
- Large hammer
- Stringline
- Level
- Wooden or steel grade stakes
- Square
- Drill and 1/4" or 3/8" masonry bit
- Core drill when possible
- Vibrator (finger type)
- Rubber mallet
- Abrasive blade (dry)
- Diamond blade and concrete saw (wet)
- Cold chisel
- Caulking gun
- Adhesive
- Shovel or spade
- Grinder
- Wire brush
- Acetone when using sealants
- 3" PVC pipe (SCH 40)
- 4" PVC pipe (SCH 35)

## Excavation

Excavation must provide for the thickness of the encapsulation concrete on ALL sides of the channel and should be sloped approximately 0.6% downhill toward the catch basin (the same approximate slope of the PolyDrain System itself). This determination must be made by the concrete design engineer. If PolyWall Sidewall Extensions are to be used, excavate an additional 7" (180mm) for Polywall 1 and 14" (360mm) for Polywall 2. Add 1.2" (30mm) of deep for frame & grate installation.

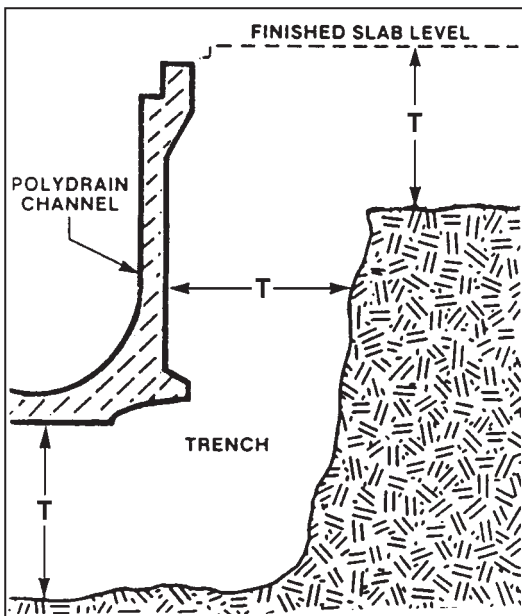

Excavation for channels  
T = Thickness of slab design

## System Layout

Each channel displays a number on the outside indicating its numerical sequence in the system as well as an arrow showing the direction of flow. Consult plans or shop drawings for the proper sequence. Channels should be laid out, in numerical sequence, alongside the completed excavation. Assure proper alignment and grade elevation with a stringline.

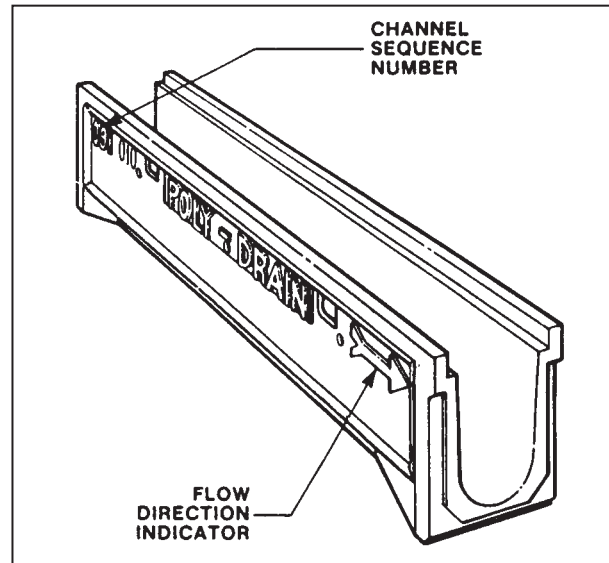

PolyDrain channel section

## Cutting Polymer Concrete and Forming Miter Joints

Miter joint cuts are made by sawing the channels to the desired angle and butting them together. A suitable adhesive can be used to bond the two sections together. If the channels are to transport a corrosive solution, an appropriate adhesive or sealant should be used.

Cutting polymer concrete for miter joints or length adjustments may be accomplished using a standard masonry or concrete saw. Water-cooled diamond encrusted blades or dry cutting abrasive masonry blades may also be used.

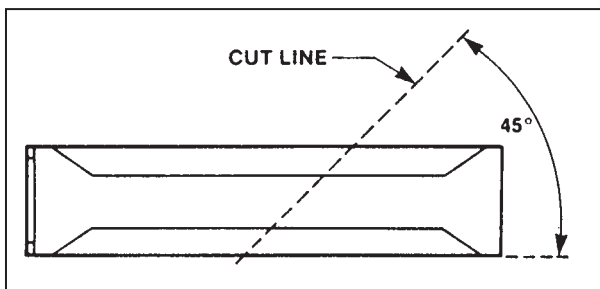

Underside of channel indicating cut line for miter

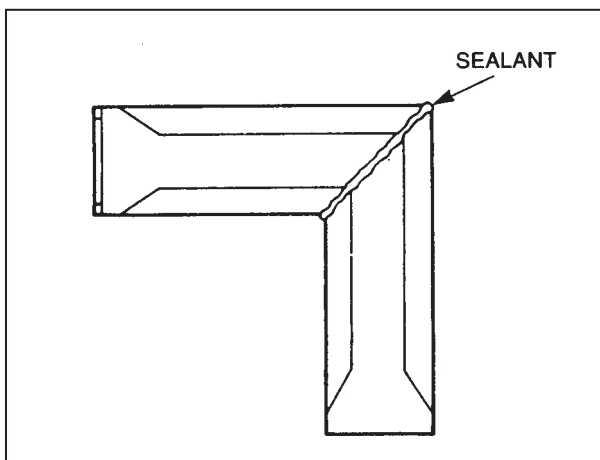

Underside of channel illustrating how to form joint

WARNING

When sawing sections of polymer concrete channel, wear gloves, protective eyeglasses and a respirator mask. Avoid breathing the airborne silica particles (created when sawing) as it may be harmful to your health.

## Piping Connections and PreFormed Cutout Removal

All catch basins and outlet channels are equipped with preformed cutouts for piping connections and channel/catch basin connections. These connections are prepared as follows:

1. Determine the cutout to be removed and mark with pencil.
2. A core drill provides the best quality hole. If one is not available, use a 1/4" or 3/8" masonry drill bit and drill holes around perimeter on 1/2" - 3/4" centers.
3. Remove the remaining fins using a hammer and a cold chisel. A grinder may be used to dress or enlarge the hole for proper pipe or channel insertion.
4. Fit pipe or channel end into hole and apply a suitable sealant. If corrosive materials are to be transported in the trench, use the appropriate sealant.

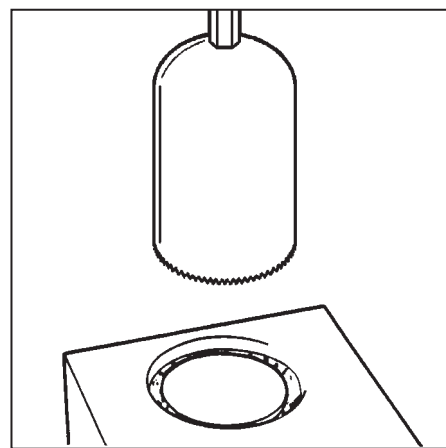

Drilling cutout with core drill

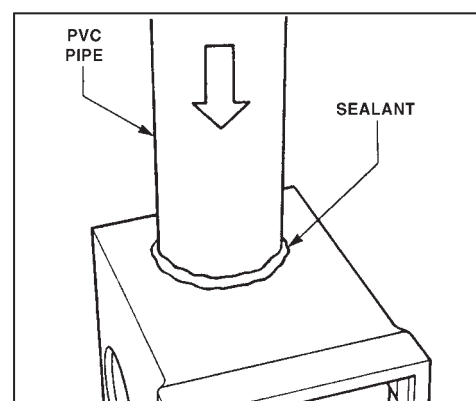

Fitting PVC pipe into catch basin

## Catch Basin Installation

Locate positions for catch basins and excavate. Remember, the depth of the bedding concrete must be at least equal to the slab thickness but not less than 4". Please consult structural engineer.

Determine which preformed cutouts are to be used and remove prior to placing catch basin in position. Larger than 6" diameter piping may be installed by fabricating larger diameter holes.

Pour bedding concrete and set catch basin on top as soon as concrete is stiff enough to support it. Set catch basin to proper grade and alignment using stringline or level.

Install pipe connections.

Backfill with concrete around the sides of the catch basin up to the channel excavation level.

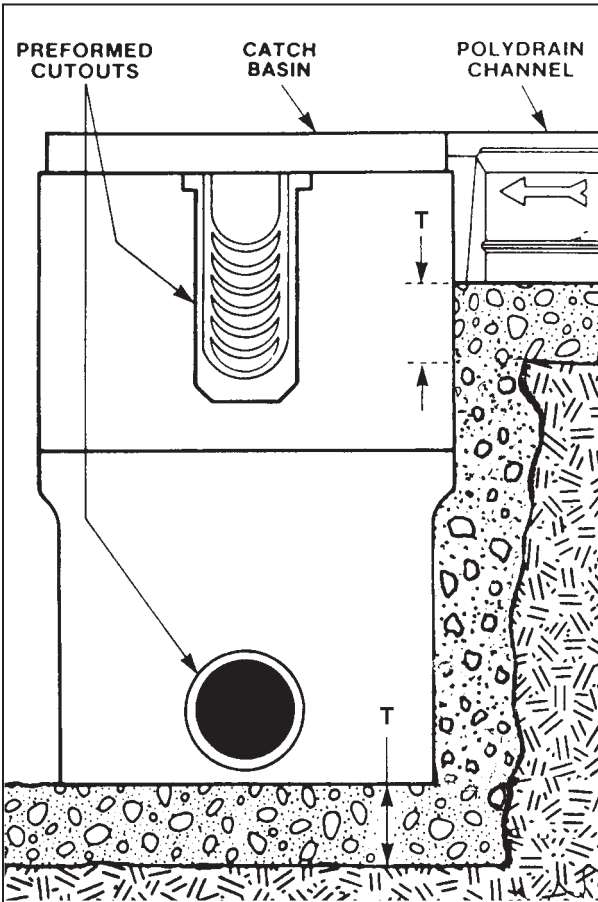

Detail of catch basin installation  
T = specified slab thickness

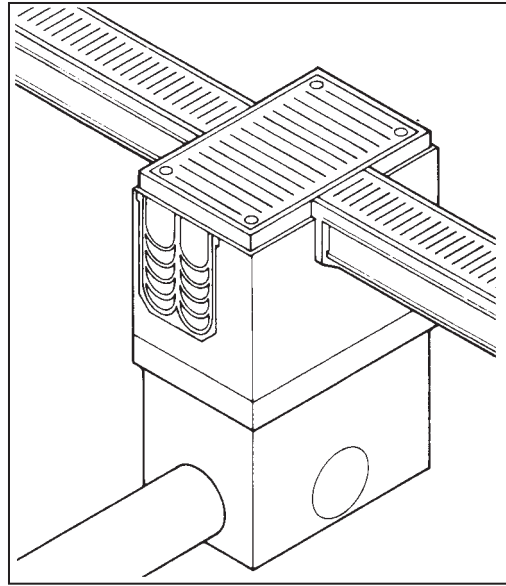

Typical 600 series catch basin installation

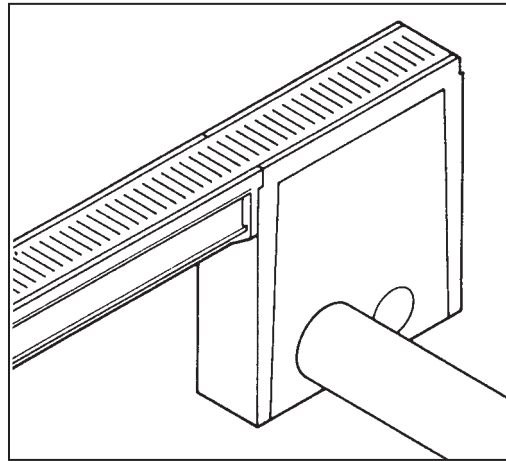

Typical 900 series catch basin installation

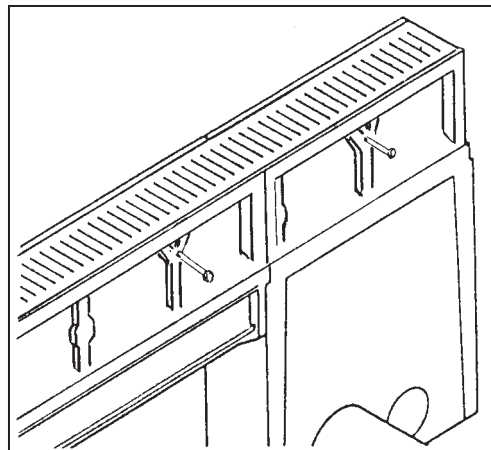

900 series catch basin installation with PolyWall Sidewall Extensions

## Horizontal and Vertical Outlet End Plates and Closed End Plates

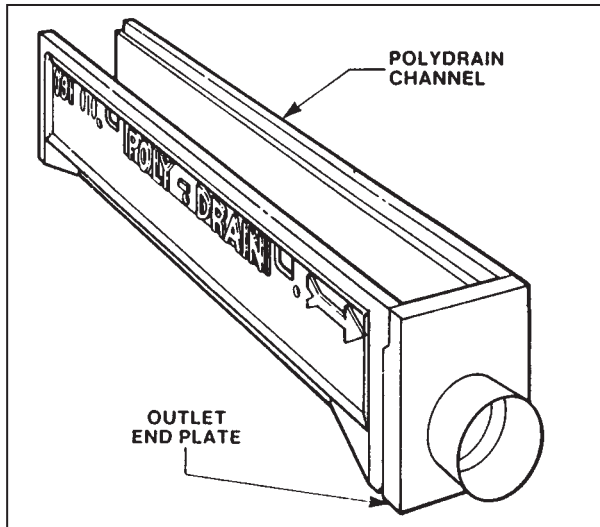

Placement of a horizontal outlet end plate on a channel

Horizontal and Vertical Outlet End Plates with PVC outlets cast into them are constructed to fit the downstream end of outlet channels. Inlet plates are available and fit on upstream end of appropriate channels.

Closed End Plates fit either the upstream or downstream end of the channels by simply reversing the plate. All inlet and outlet plates may be held in place using ABT sealants.

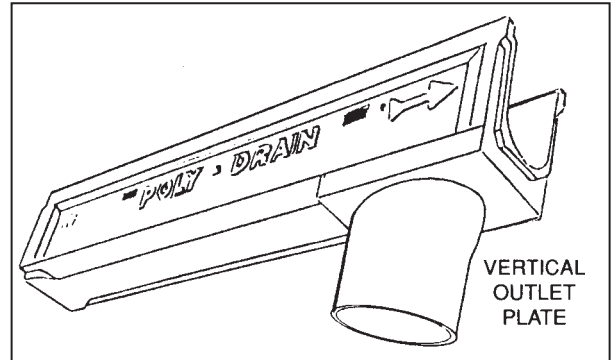

Placement of vertical outlet plate on underside of channel.  
NOTE: When using PolyClips with vertical outlet adapter, install PolyClip closer to center of channel so as not to interfere with outlet plate.

## Installation of Channel Across Expansion/Contraction Joints in Floor Slab

Follow this procedure when installing a channel across an expansion/contraction joint in a floor slab:

1. Mark the channel where it crosses the expansion/contraction joint and saw the channel in two at that point.
2. Separate the two channel pieces by a width equivalent to the width of the expansion/contraction joint itself.
3. Fill this space with flexible joint material. See "Sealants" Section for recommendations on which type of caulk to use for your particular situation.
4. Control joints are best located at channel joints to reduce channel cracking.

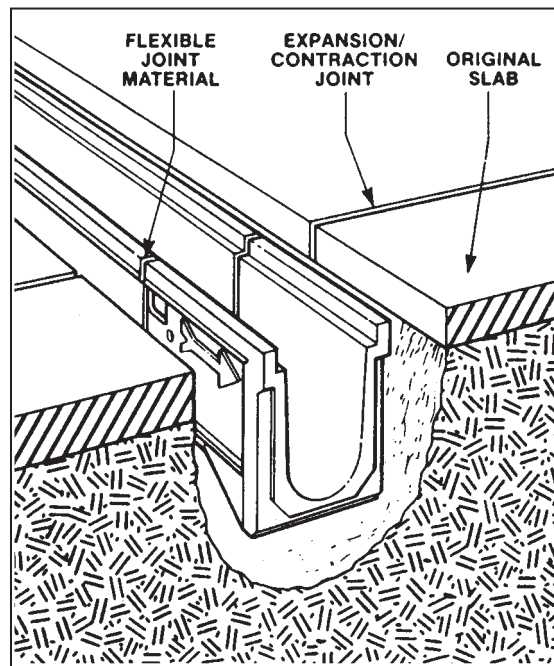

Channel installed across an expansion/contraction joint

## Grating Installation Prior to Concreting

### NOTE:

THE GRATES MUST BE IN PLACE PRIOR TO CONCRETING SINCE THEY AID IN MAINTAINING ALIGNMENT AND JOINT SMOOTHNESS.

Wrap the grates in Poly or mask with duct tape and place them in the channel grate lip so that they span the channel joints as shown at right or place grates upside down. Locking the grates in place will help secure channel alignment. A shim placed between the grate and the upright edge of the channel grate lip is necessary for the grate to fit properly after concreting.

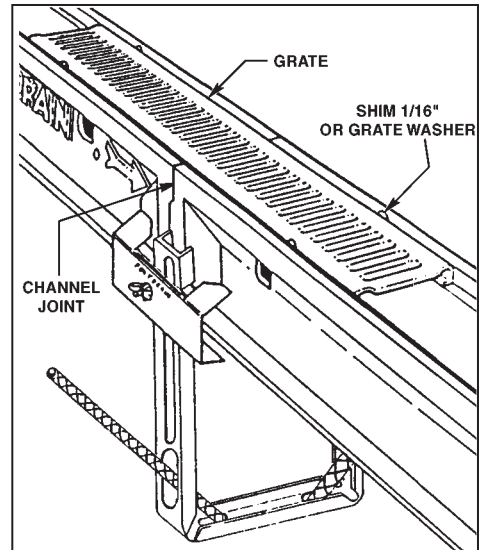

Placement of grate across channel joints

## Alternate to Grating Installation Prior to Concreting

As an alternate to placing covered gratings in the channel prior to concreting, strips of 3/4" plywood "ripped" to 4-15/16" wide can be used. Since this width is slightly wider than the grate itself, it is not necessary to place shims in the upright edge of the channel/sidewall grate lip as before. As with the gratings, the plywood strips must also span the channel joints. These strips provide a complete cover for the trench during concreting, thus eliminating having to clean concrete spillage out of the trench before final grate installation.

The plywood strips may be oiled for reuse on future installations.

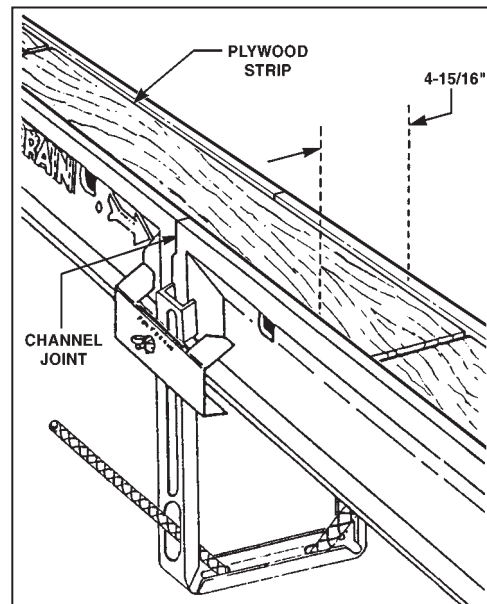

Placement of plywood strip across the channel joint

## Channel Installation (General)

**Note:**

Always begin installation at outlet or discharge end of each run and work backwards (upstream). Each side of every channel has an arrow indicating the direction of flow. The arrow always points toward the outlet (downstream). See illustration.

Before actually installing the channels, you must follow the procedures for:

- Piping connections and preformed cutout removal;
- Catch basin installation; and
- Cutting polymer concrete and forming miter joints.

There are four (4) basic methods of PolyDrain channel installation discussed in these notes:

- 1) PolyClip installation devices;
- 2) PolyWing Hanger installation devices;
- 3) Suspended installation; and
- 4) Bedding slurry installation.

The method you choose will depend on soil type, whether or not it is a retrofit installation, and other various factors.

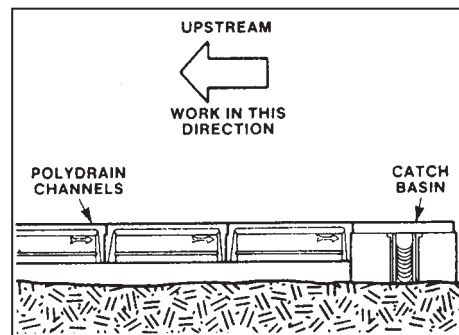

Order of channel installation

## Channel Installation with PolyClip®

The PolyClip consists of; 1) two securing clips (one for each side of the channel); 2) a "U"-shaped, no-float support leg that maintains proper channel height and prevents channel flotation during the concrete pour; and 3) a threaded crossrod that keeps the PolyClip secured to the channel. PolyClip installation aids, when properly attached to channels, will maintain proper channel alignment and assist in drawing the channel joints together.

1. Excavate trench as previously described, allowing enough room under channels for the specified slab thickness (minimum 4").
2. Set a stringline to the finished slab height at the outside edge of the proposed channel location.
3. Layout channels in numerical sequence upside-down alongside the trench.
4. If sealant is to be used, apply it to channel joints at this time.

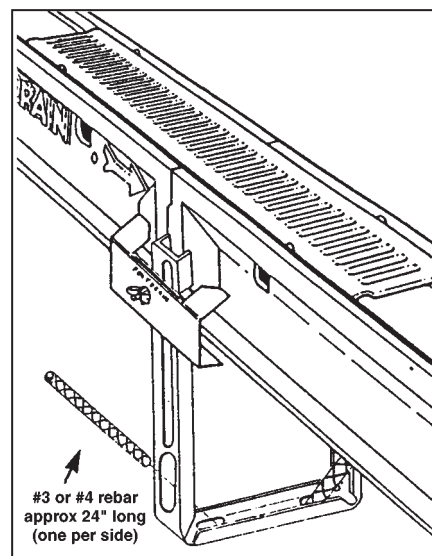

A - Attach the PolyClip at the joint of butting channels  
NOTE: PolyClips may be required to be shimmed up depending on design thickness of structural slab.

5. Starting at the deep end, butt channel sections together. Assemble the two brackets to the sides of channel ends as shown, by backing the wingnuts to the end of the threaded crossrod and spreading the clips to their limit. Temporarily hand tighten the wingnuts after installing them on the channel.
6. Position channel sections in the trench right side-up. Starting at the discharge end, adjust the channel sections to the correct slab height as shown by the stringline by sliding the no-float leg up or down on the PolyClip. Tighten the wingnuts to secure final position.
7. Connect a PolyClip to the upstream end of the last channel positioned. Position the next channel, and spread the clip assembly so the next upstream channel can be attached. Continue this procedure until all upstream channels have been properly positioned.
8. Before initiating the concrete placement, insure that all channels are properly positioned for slab height and alignment in the trench.
9. To guarantee that channels will not float, several methods can be used to secure them to the subgrade:

A. **Two stage concrete placement** - Anchoring concrete should be placed over the no-float legs (minimum two inch depth) across the entire width and length of the excavation. Allow the concrete to set hard. (Dia. B)

B. **Rebar anchoring** - If the site has suitable conditions, drive a length of #3 or #4 rebar diagonally through the holes provided in the no-float leg on both sides of the channel. (Dia. A)

C. Weld, nail or screw the no-float legs to form work.

(Caution should be taken to direct the concrete placement under the channels, not directed at channel sidewalls, thus insuring that proper channel alignment is maintained.)

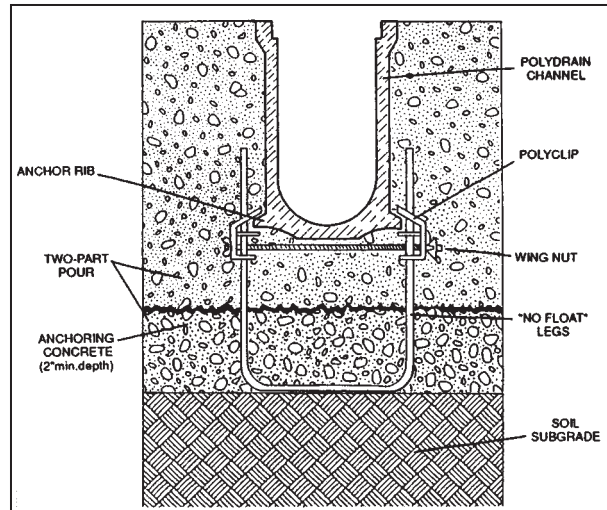

B - The first concrete placement should cover the entire width and length of the excavation, covering no-float legs by at least 2"

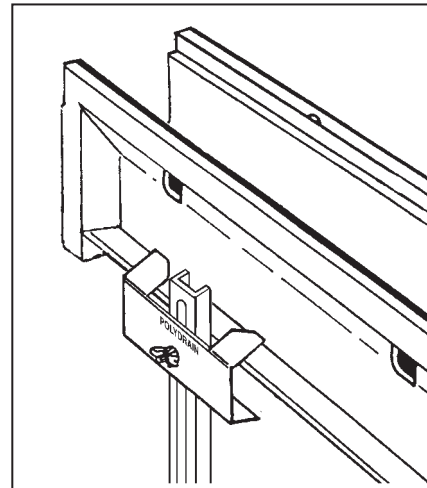

Slip PolyClip back along the anchor rib of final upstream channel

## Channel Installation using PolyWing Hangers

The PolyWing Hanger method of installation can also be used in place of the suspended installation method when a wider gap between floor slab sections is encountered, or when an unusually thick slab is required. Rocky or sandy soil conditions are not typically suitable for PolyWing hanger installations.

1. Place channels upright in the bottom of the trench. Align channels with the stringline, butting channels end-to-end. (Apply appropriate sealant at this time if necessary.)
2. Place PolyWing Hangers across top of channel directly above the "Red Dot/Green Dot" PolyLock Blocks and secure the hangers to the channels using PolyLock lock toggles.
3. Drive #4 rebar through the clamps on both sides of the PolyWing Hangers attached to the channels.
4. Length of rebar required should be at least twice the depth of the excavation. (When driving the rebar into the soil, allow at least 3" at the top of the rebar to extend above the level of the stringline.)
5. With rebar in place, slide channels up until the top edges of the channels align with the stringline. Secure in position by tightening the clamps around the rebar

6. With all channels in position, begin a two stage placement of concrete, using enough concrete to cover the entire trench bottom and fill past the anchor ribs (about one-third up the channel wall).
7. Follow accepted concrete practices to address cold joint conditions.
8. Allow concrete to set.
9. Detach PolyWing Hangers from the channels, loosen the clamps around the rebar and remove PolyWing Hangers. Cut off excess rebar or bend over so that rebar is below finished grade.
10. Place and finish concrete, then secure grates into channels.

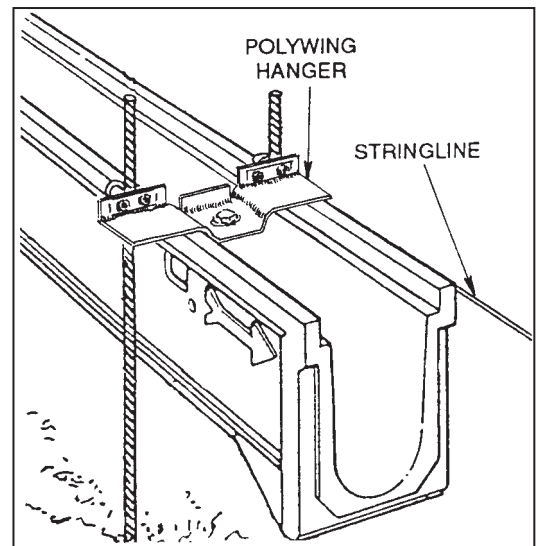

Slide channels with PolyWing Hangers up the rebar until channels are properly aligned with the stringline

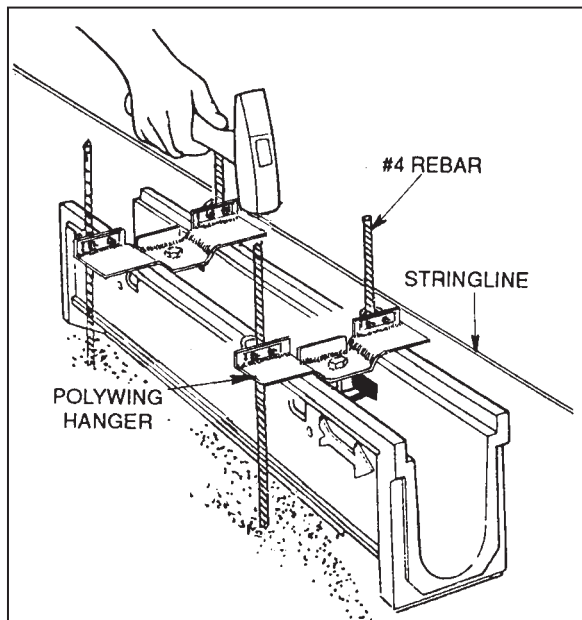

Driving rebar through PolyWing clamps

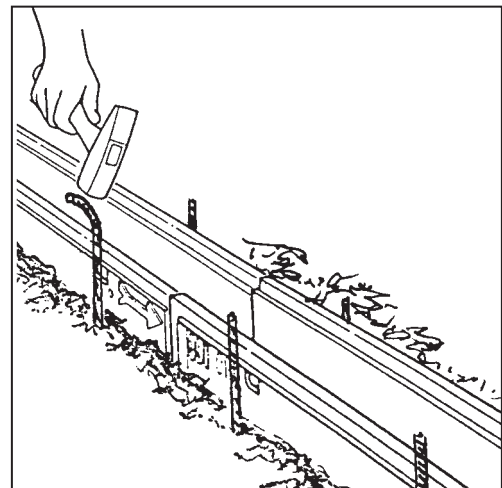

With the first pour set and PolyWing Hangers detached, bend top of rebar over or cut of below finished grade

## Channel Installation by Suspended Method

This method of channel installation is ideal for retrofit installations (where parts of an existing slab must be removed for insertion of a trench drain), or installations where form work is required. Cut 2 x 4's a minimum of 4" wider than the excavated trench. Pre-drill a 1/2" hole in the center of the 2 x 4.

Channels are suspended from pre-bored 2 x 4 boards using 4-1/2" long bolts and toggle bars (properly positioned in the "Red Dot/Green Dot" PolyLock lock block) to securely support the channel while concreting. The 2 x 4 board must span the width of the trench and be supported by an existing finished surface (such as concrete or asphalt) or the boards may be supported by a structure of form work. In order to assure the grating will be slightly lower than the level of the surrounding concrete, insert shims (flat washers or wood shims at least 1/8" deep) on the top edge of both sides of the channel (between the board and the channel). This will prevent puddling next to the drainage system and will aid in the positive flow of liquids into the channel. Adjust the channel, sliding it forward or backward, to insure a tight connection between the tongue and groove butt joints at the channel ends. (Seal joints with appropriate sealant if required.)

Before placing concrete around the channel, be sure that all 2 x 4 boards are secured against channel flotation. To secure the boards, nail them to the original slab or weight the ends. If a single placement is desired, place 2 x 4 blocks under the 2 x 4 board at the channel edges and at the slab. Finished grade can then be troweled off with no obstructions.

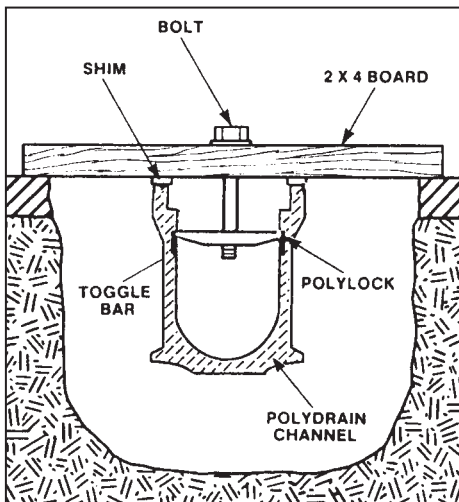

End view of suspended channel installation

## Channel Installation with Bedding Slurry

If the installation bracket or suspended installation method is not practical to use, you may install the PolyDrain channels using concrete bedding slurry (slump equals 1-2 inches). The thickness of the concrete bedding should be the designed thickness of the slab (minimum 4").

Place patties of stiff concrete under the "Red Dot/Green Dot" Lock Block locations. Lay the channels in the bedding slurry and consolidate concrete above the anchoring rib on each side of the channel. Check alignment and grade of the channel before the concrete stiffens.

Adjust the channel, sliding it forward or backward, to insure a tight connection between the tongue and groove butt joints at the channel ends. (Seal joints with appropriate sealant if required.) Once channels are locked in position, and the bedding slurry has set concrete can be placed to finished grade. **DO NOT CHUTE CONCRETE DIRECTLY AGAINST CHANNEL WALLS.**

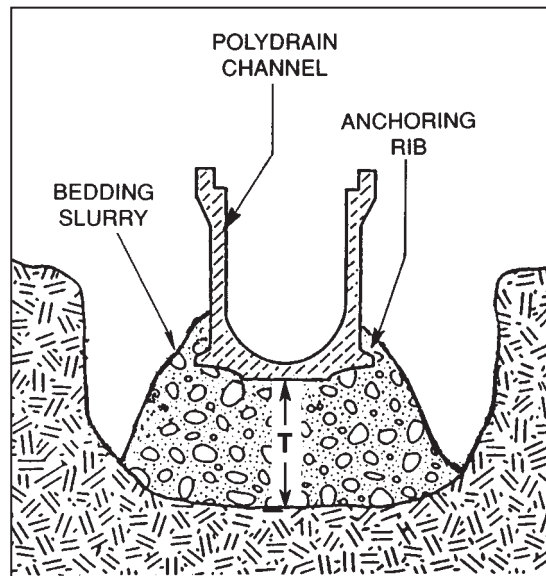

Placement of channel in concrete bedding slurry  
T = thickness of slab design

## PolyWall Sidewall Extension Installation

PolyWall Sidewall Extensions allow channel runs of up to 90 meters (297 feet) without the use of non-sloping channels and greatly increase the flow capacity of the system.

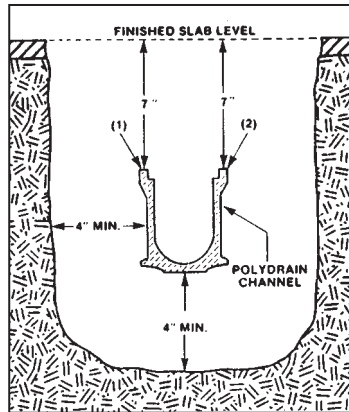

**NOTE:**  
Add 1.2" to overall depth when using frame & grate system

Minimum excavation requirements for PolyWall I installation  
T = Thickness of slab design (minimum 4")  
Note: If using PolyWall II wall is 14" in height.

**NOTE:**

**EXCAVATE DEEP ENOUGH TO ENSURE THAT STRINGLINE GUIDE POINTS ARE SET 7" (180mm) BELOW THE DESIRED FINISHED GRADE TO ALLOW FOR THE HEIGHT OF THE POLYWALL I and 14" (360mm) FOR POLYWALL II.**

A. To install PolyWall Sidewall Extensions using installation devices:

1. Install the channels following the instructions for the selected method.
2. Place concrete above lower anchoring rib as shown below. **DO NOT CHUTE CONCRETE DIRECTLY AGAINST CHANNELS!** Allow concrete to set up enough to prohibit channel movement. Refer to section on "Concreting,". Use standard cold joint precautions.
3. Attach three PolyWall anchor bolts on the outside of each PolyWall Sidewall Extension.
4. Set Polywall on top of each side of the channel, fitting the preformed groove on the PolyWall over the top edge of the channel.
5. Notch end of 300 channel for proper fit when transitioning from PolyWall I to PolyWall II.

6. Set covered grates or 4-15/16" wide, pre-bored plywood strips into the Polywall grate lip. Then place a 5/16" threaded rod or correct length bolt through the hole provided in the grate or plywood and thread a toggle bar on the end. Turn the bolt until the toggle bar slips into the "Red Dot/Green Dot" PolyLock depression in the channel side and snugs the channel and PolyWall together. Before tightening lock bolt, be sure that channel and Polywall ends are flush and that PolyWalls are plumb. If covered grates are used here instead of plywood strips, place shims (flat washers 1/8" thick between the grate and the upright edge of the PolyWall grate lip to insure the grate will fit properly after concreting. Check for alignment and grade then fill the remaining space on both sides of the PolyWall with concrete. **DO NOT CHUTE CONCRETE DIRECTLY AGAINST CHANNELS OR POLYWALLS!**

7. Refer to sections on "Concreting" and "Cleanup and Final Grate Installation" for information on finishing the installation.

B. To install PolyWall Sidewall Extensions using the Suspended System:

1. Attach 3 PolyWall anchor bolts on the outside of each PolyWall Sidewall Extension.
2. Set PolyWall on top of each side of the channel, fitting the preformed groove on the Polywall over the top edge of the channel.
3. Insert a 5/16"-18 UNC threaded rod, first, through a pre-bored 2 x 4 board (the board

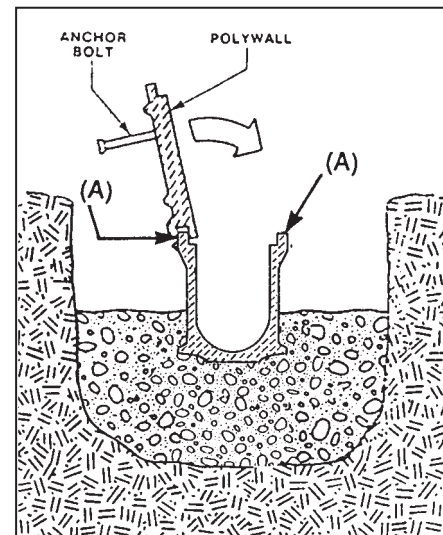

End view of PolyWall placement on channel

must be long enough to span the width of the trench) then, through a covered grate or a 4-15/16" wide, pre-bored plywood strip. Screw a toggle bar onto the end of the bolt. Place the 2 x 4, the grate or plywood, and the bolt assembly on the top edge of the PolyWall and turn the bolt until the toggle bar slips into the red "PolyLock" depression in the channel side and snugs the channel and PolyWall together. Remember to insert shims (a flat washer 1/8" thick) between the top edge of the PolyWall and the board to insure that the grating will be slightly lower than the level of the surrounding concrete. Also place shims between the grate and the upright edge of the PolyWall grate lip (if grates are used prior to concreting). This will insure that the grate will fit properly after concreting.

5. Lower the entire assembly into the trench, supported either by the existing floor slab or by a structure of form work.
6. Check for alignment and grade. Place bedding concrete as described in the section on "Concreting". **DO NOT CHUTE CONCRETE DIRECTLY AGAINST CHANNEL WALLS.**

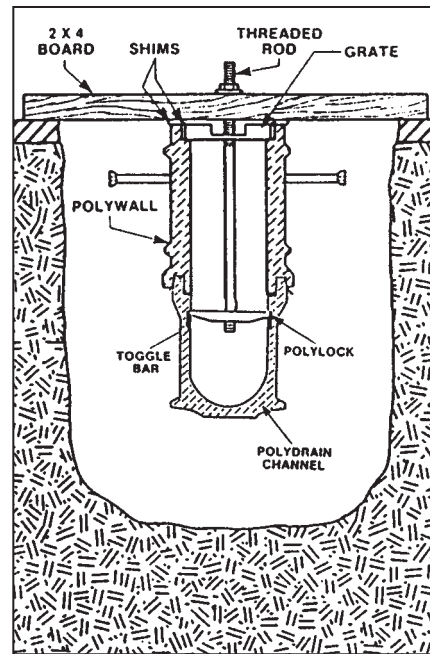

Suspended method with PolyWall Sidewall extensions

## Concreting

NOTE: Concrete must conform to specified standards for thickness and strength and must be placed following the same procedure whether the finished surface will be asphalt pavement or concrete. When installing channels using the bedding slurry method slump must equal 1"-2".

NOTE: The trench excavation must allow for the thickness and reinforcement specified by the designer or structural engineer.

REMINDER: Concrete should be placed in the trench in a manner so as not to disturb the properly aligned channel system. **DO NOT CHUTE CONCRETE DIRECTLY AGAINST CHANNELS!!**

Work concrete under channels and vibrate with a finger-type vibrator.

The top edge of the channels or sidewalls may be used as a screed rail during concrete placement. If a light, motorized vibratory screed is used, it is necessary to first make a placement of concrete to a height of approximately 1/2" above the lower anchoring rib of the channel or, when installing sidewalls, above the lower anchoring rib of the sidewall. Then allow concrete to set up before placing next layer and placing screed on channel/sidewall edge.

NOTE: When placing concrete in multiple layers (one, to fill just above lower anchoring rib, and two or more, to fill in the remainder), be sure that the last placement will be at least 6" thick to avoid cracking of the top layer.

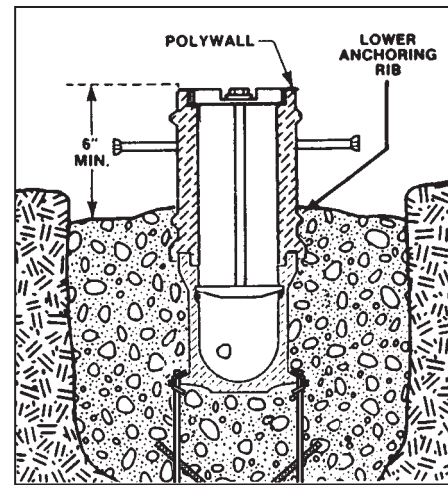

Concrete placed above lower anchoring rib of PolyWall

It is recommended the finish level of the concrete be between 1/8" and 1/16" above or at least level with the top edge of the channel or sidewall.

A finished slope of 1/8" per foot for two feet on each side of the trench is also recommended. This will provide a positive drainage flow into the channel system.

## Cleanup and Final Grate Installation

1. Remove and clean gratings.
2. Clean all debris and any concrete spillage out of trench and catch basins.
3. Insert the grate bolt through the hole provided in each grate.
4. Screw the toggle bar onto the bolt with two full turns.
5. Set the grate into the channel/sidewall grate lip. Hand tighten the bolt until the toggle bar slips into the "Red Dot/Green Dot" PolyLock depression in the side of the channel and snugs the grate into place.
8. Tighten lock bolt securely with a wrench.

**The Polydrain System is now complete and ready for operation!**

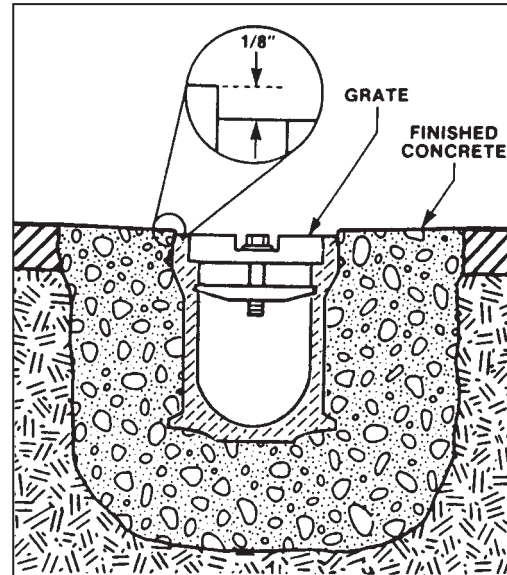

Final grate installation

**For technical assistance contact  
the ABT Sales Support Team  
800-438-6057**

The information contained within is believed to be accurate but not guaranteed to be so. The customer should evaluate the suitability and safety of these products for any application. ABT assumes no liability for the end results since the conditions of installation and use are beyond the control of ABT. Concrete specifications, placement, reinforcement and structural considerations are the responsibility of the customer. ABT reserves the right to change the price, availability, specifications, and content of any of its products, literature or other information in all media at any time without notification.

**ABT, INC.**