

PolyDrain®

Pre-Engineered Surface Drainage Manual

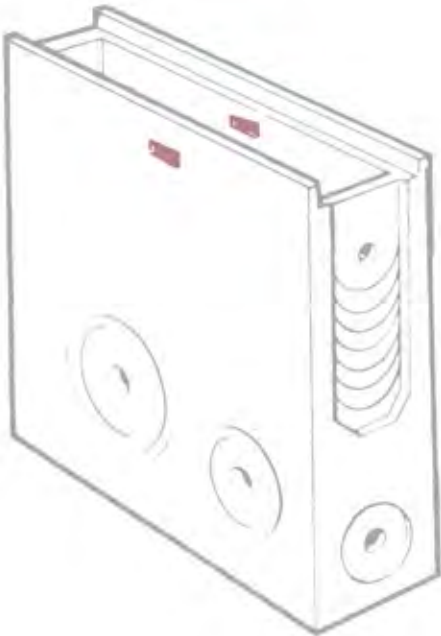
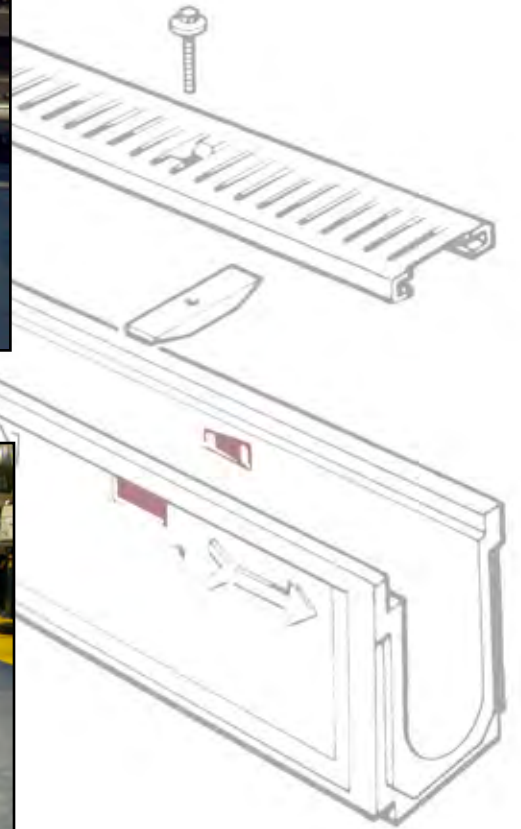
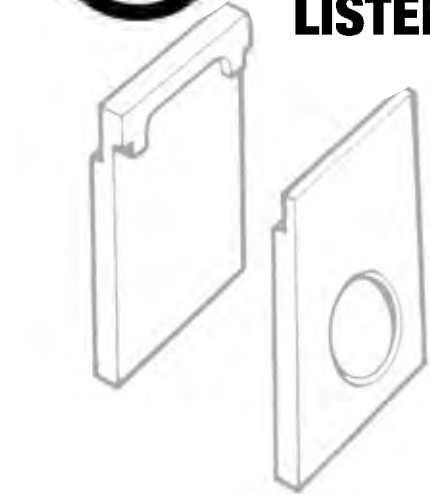

ABT, INC.

www.abtdrains.com

Today's Hydraulic Solutions





ABT, Inc. manufactures PolyDrain trench drains; the standard for pre-engineered trench drains. Over the years the PolyDrain name has become synonymous with trench drain design. Architects and engineers, recognizing the benefits of pre-engineered polymer concrete trench drains, specify PolyDrain for a wide variety of applications. Included among these applications are food processing plants, airports, highways, loading docks, garden centers and chemical processing plants.

PolyDrain polymer concrete trench drain assures the specifier of the precision and accuracy required to satisfy hydraulic or chemical resistant demands. PolyDrain offers design flexibility, as well as ease of installation. In addition, expensive labor and material costs associated with hand-forming methods are eliminated.

PolyDrain channels are a nominal meter (39.19 in., 3.27 ft.) long. Standard channels have a 0.6% built in slope. The 30 standard channels are positioned sequentially in numerical order from 010 to 300, creating a continuously sloped channel run. Channel runs can be designed with intersections or miters and fabricated onsite utilizing commercial grade cutting tools. With PolyDrain, runs of almost any length are possible by varying outlet placements, integrating non-sloping channels and using PolyWall Sidewall Extensions for increased depth.

Flammability and NFPA Codes

Trench drains are often the collection point for flammable liquids and heavier than air vapor, and can contribute to the spread of fire. Selecting a trench drain with the proper material properties is critical to the life cycle of the product and life safety of a buildings inhabitants.

ABT Inc's Polyester Polymer Concrete products carry the UL-723 Classified mark for Class A fire rating. Demand a UL Classified product.

PolyDrain Formulations

ABT offers two compositional formulations for PolyDrain channels, depending on the effluent and chemical environment. Both offer superior strength and durability as well as marked cost advantages over alternative materials.

Standard PolyDrain channels are manufactured from PolyDyn®, an advanced formulation of selected quartz aggregates and inert mineral fillers bonded together in a high-grade polyester resin. This formulation is suitable for use in both exterior and interior applications.

When a higher level of chemical resistance is required, ABT offers PolyDrain in a special formulation called PolyChampion®, which has the same quartz and mineral fillers as the PolyDyn formulation, but with a premium grade vinyl ester resin binder. This formulation will withstand a broader range of corrosive salts, fuels, acids and alkalis.

Comparative Analysis

Fluid	Polymer Concrete		Portland Cement
	PolyDyn	PolyChampion	
Water	✓	✓	Permeable
Gasoline	✓	✓	Permeable
Diesel Fuel	✓	✓	Permeable
Aviation Fuel	✓	✓	Permeable
Hydraulic Oil	✓	✓	Permeable
Fuel Oil	✓	✓	Permeable
Hydraulic Fluid	✓	✓	Permeable
Motor Oil	✓	✓	Permeable
Sea Water	✓	✓	Permeable
Acids		✓	Corrodes
Road Salts	✓	✓	Corrodes

Polymer Concrete is resistant to salt, oil, gas, sewage, most acids and many alkalis. This makes it excellent for chemical transport, washdown and food processing, as well as many other applications.

Physical Properties of PolyDyn® Thermoset Polyester Polymer Concrete		
Property	Test Method	Value
Compressive Strength	ASTM C579	17,000 psi Minimum
Bending Strength	ASTM C580	4,000 psi Minimum
Tensile Strength	ASTM C307	2,000 psi Minimum
Moisture Absorption	ASTM C140	0.2% Maximum
Chemical Resistance	ASTM C267	Pass- Automotive Fluids
Freeze/Thaw (1,600 Cycles)	ASTM C666	No Weight Loss
Fungi Growth Resistance	ASTM G21	Zero Mold Growth
Flame Spread - UL/ULC	UL 723	Class A

Typical PolyDrain System

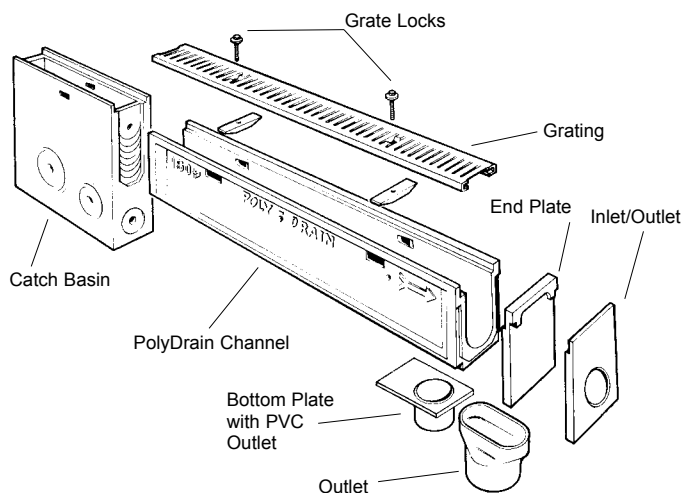

Interlocking Joints

PolyDrain channels have interlocking tongue-and-groove joints that serve two important functions. First they aid in maintaining proper channel alignment during the pour. Second, they assist in securing channel connections to prevent fluid migration out of the system. ABT maintains a line of sealants that can be applied to channels when a sealed system is required.

Pre-Sloped Radius Channels

Standard PolyDrain channels have a built-in 0.6% slope with a smooth radius bottom and a narrow cross section. These features provide excellent hydraulic efficiency. Without any site slope, a 3.5 feet per second velocity is obtained when the channels are flowing full.

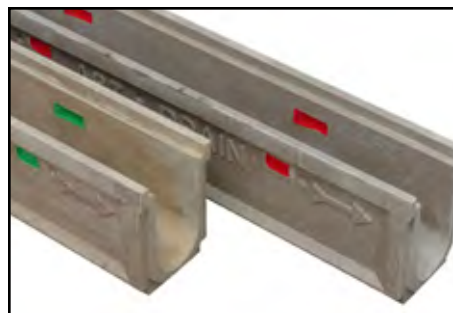

PolyLock™ Inserts

PolyDrain channels feature RedDot® polyethylene inserts or GreenDot® polypropylene inserts. These inserts, together with the grate locking devices comprise the PolyLock grate lockdown system. RedDot inserts also provide vibration dampening that helps keep grates secure under traffic conditions.

Anchoring Ribs

PolyDrain channels are formed with full-length anchoring ribs on each side of the channel at the base of the side wall. These anchoring ribs provide a positive mechanical lock with surrounding concrete.

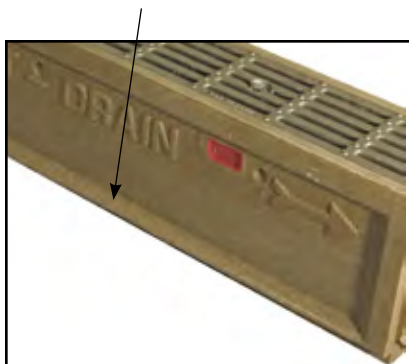

DISCLAIMER

The customer and the customer's architects, engineers, consultants and other professionals are completely responsible for the selection, installation, and maintenance of any product purchased from ABT, and EXCEPT AS EXPRESSLY PROVIDED IN ABT'S STANDARD WARRANTIES, ABT MAKES NO WARRANTY, EXPRESS OR IMPLIED, AS TO THE SUITABILITY, DESIGN, MERCHANTABILITY, OR FITNESS OF THE PRODUCT FOR CUSTOMER'S APPLICATION. Copies of ABT's standard warranties are available upon request.

PolyDrain®, PolyDyn®, PolyChampion®, GreenDot®, RedDot® and PolyWall® are registered trademarks of ABT, Inc.®

The PolyDrain Trench Drain System consists of 30 interlocking sloped channels and 4 non-sloped channels. Special non-sloping channels can be inserted at specified intervals in order to extend channel runs. Catch basins, horizontal outlet plates, closed end plates and vertical outlet plate adapters can be installed at designated locations. Closed end plates terminate channel runs. To determine number of channels required simply divide footage by 3.27.

NOTE: Always begin at the appropriate outlet channel, working towards the shallow end.

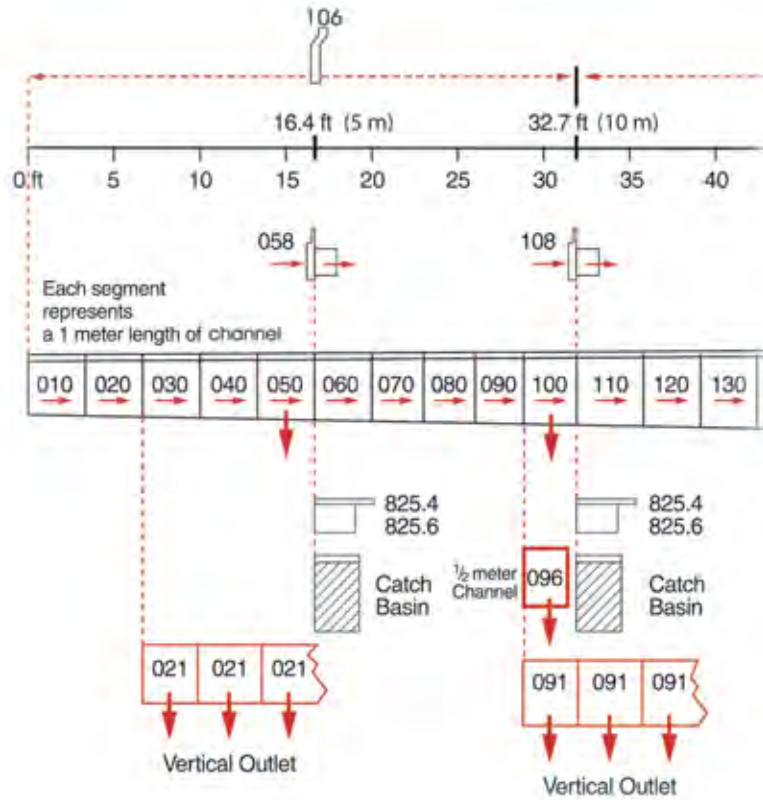

Channel Specifications

Use this chart to estimate flow capacities and invert elevations. Add a minimum of 4" to overall depths to estimate necessary excavation or as recommended by Structural Engineer. Actual depth of excavation is governed by slab or pavement thickness.

When using the Model 510 or 530 Series frame and grate systems, add 1.2 in. (31 mm) to the overall depths.

NOTES:

Subtract 1 in. (25 mm) from minimum and maximum depths shown to obtain invert elevations.

Red part numbers indicate non-sloping channels.

Hydraulic data does not have a grate locking device in flow area.

Part No.	Channel Only				Channel With PolyWall I			
	Overall Channel Depth in. (cm)		Maximum Flow Rate gpm (lpm)	Weight lbs (kg)	Overall Channel Depth in. (cm)		Maximum Flow Rate gpm (lpm)	Weight lbs (kg)
	Minimum	Maximum			Minimum	Maximum		
010	5.1 (12.9)	5.3 (13.5)	106.7 (403.8)	31.1 (14.1)	12.2 (30.9)	12.4 (31.5)	389.9 (1476.1)	82.9 (37.6)
020	5.3 (13.5)	5.6 (14.1)	115.8 (438.3)	32.8 (14.9)	12.4 (31.5)	12.6 (32.1)	399.5 (1512.4)	84.6 (38.4)
021	5.6 (14.1)	5.6 (14.1)	—	32.0 (14.5)	12.6 (32.1)	12.6 (32.1)	—	83.8 (38.0)
030	5.6 (14.1)	5.8 (14.7)	125.0 (473.1)	33.6 (15.2)	12.6 (32.1)	12.9 (32.7)	409.1 (1548.7)	85.4 (38.7)
040	5.8 (14.7)	6.0 (15.3)	134.2 (508.0)	34.3 (15.5)	12.9 (32.7)	13.1 (33.3)	418.7 (1584.9)	86.1 (39.0)
050	6.0 (15.3)	6.3 (15.9)	143.5 (543.0)	33.8 (15.3)	13.1 (33.3)	13.3 (33.9)	428.3 (1621.2)	85.6 (38.8)
060	6.3 (15.9)	6.5 (16.5)	152.7 (578.2)	35.2 (16.0)	13.3 (33.9)	13.6 (34.5)	437.9 (1657.6)	87.0 (39.5)
070	6.5 (16.5)	6.7 (17.1)	162.1 (613.5)	36.2 (16.4)	13.6 (34.5)	13.8 (35.1)	447.5 (1693.9)	88.0 (39.9)
080	6.7 (17.1)	7.0 (17.7)	171.4 (648.9)	37.0 (16.8)	13.8 (35.1)	14.0 (35.7)	457.1 (1730.2)	88.8 (40.3)
090	7.0 (17.7)	7.2 (18.3)	180.8 (684.3)	38.0 (17.2)	14.0 (35.7)	14.3 (36.3)	466.7 (1766.5)	89.8 (40.7)
091	7.2 (18.3)	7.2 (18.3)	—	37.4 (17.0)	14.3 (36.3)	14.3 (36.3)	—	89.2 (40.5)
096	7.2 (18.3)	7.2 (18.3)	—	20.1 (9.1)	14.3 (36.3)	14.3 (36.3)	—	71.9 (32.6)
100	7.2 (18.3)	7.4 (18.9)	190.2 (719.9)	37.6 (17.1)	14.3 (36.3)	14.5 (36.9)	476.3 (1802.9)	89.4 (40.6)
110	7.4 (18.9)	7.7 (19.5)	199.6 (755.5)	39.8 (18.1)	14.5 (36.9)	14.8 (37.5)	485.9 (1839.2)	91.6 (41.5)
120	7.7 (19.5)	7.9 (20.1)	209.0 (791.2)	40.6 (18.4)	14.8 (37.5)	15.0 (38.1)	495.5 (1875.6)	92.4 (41.9)
130	7.9 (20.1)	8.2 (20.7)	218.5 (826.9)	42.4 (19.2)	15.0 (38.1)	15.2 (38.7)	505.1 (1912.0)	94.2 (42.7)
140	8.2 (20.7)	8.4 (21.3)	227.9 (862.7)	42.8 (19.4)	15.2 (38.7)	15.5 (39.3)	514.7 (1948.4)	94.6 (42.9)
150	8.4 (21.3)	8.6 (21.9)	237.4 (898.6)	42.6 (19.3)	15.5 (39.3)	15.7 (39.9)	524.3 (1984.7)	94.4 (42.8)
160	8.6 (21.9)	8.9 (22.5)	246.9 (934.4)	44.2 (20.0)	15.7 (39.9)	15.9 (40.5)	533.9 (2021.1)	96.0 (43.5)
170	8.9 (22.5)	9.1 (23.1)	256.3 (970.4)	45.1 (20.5)	15.9 (40.5)	16.2 (41.1)	543.5 (2057.5)	96.9 (44.0)
180	9.1 (23.1)	9.3 (23.7)	265.8 (1006.3)	46.1 (20.9)	16.2 (41.1)	16.4 (41.7)	553.2 (2093.9)	97.9 (44.4)
190	9.3 (23.7)	9.6 (24.3)	275.4 (1042.3)	46.8 (21.2)	16.4 (41.7)	16.7 (42.3)	562.8 (2130.3)	98.6 (44.7)
191	9.6 (24.3)	9.6 (24.3)	—	46.6 (21.1)	16.7 (42.3)	16.7 (42.3)	—	98.4 (44.6)
200	9.6 (24.3)	9.8 (24.9)	284.9 (1078.3)	46.9 (21.3)	16.7 (42.3)	16.9 (42.9)	572.4 (2166.8)	98.7 (44.8)
210	9.8 (24.9)	10.0 (25.5)	294.4 (1114.4)	48.6 (22.0)	16.9 (42.9)	17.1 (43.5)	582.0 (2203.2)	100.4 (45.5)
220	10.0 (25.5)	10.3 (26.1)	303.9 (1150.5)	49.8 (22.6)	17.1 (43.5)	17.4 (44.1)	591.6 (2239.6)	101.6 (46.1)
230	10.3 (26.1)	10.5 (26.7)	313.5 (1186.6)	50.0 (22.7)	17.4 (44.1)	17.6 (44.7)	601.3 (2276.0)	101.8 (46.2)
240	10.5 (26.7)	10.7 (27.3)	323.0 (1222.7)	51.5 (23.4)	17.6 (44.7)	17.8 (45.3)	610.9 (2312.5)	103.3 (46.9)
250	10.7 (27.3)	11.0 (27.9)	332.6 (1258.9)	50.5 (22.9)	17.8 (45.3)	18.1 (45.9)	620.5 (2348.9)	102.3 (46.4)
260	11.0 (27.9)	11.2 (28.5)	342.1 (1295.0)	52.4 (23.7)	18.1 (45.9)	18.3 (46.5)	630.1 (2385.3)	104.2 (47.2)
270	11.2 (28.5)	11.5 (29.1)	351.7 (1331.2)	53.0 (24.0)	18.3 (46.5)	18.5 (47.1)	639.8 (2421.8)	104.8 (47.5)
280	11.5 (29.1)	11.7 (29.7)	361.2 (1367.4)	54.5 (24.7)	18.5 (47.1)	18.8 (47.7)	649.4 (2458.2)	106.3 (48.2)
290	11.7 (29.7)	11.9 (30.3)	370.8 (1403.6)	54.9 (24.9)	18.8 (47.7)	19.0 (48.3)	659.0 (2494.7)	106.7 (48.4)
291	11.9 (30.3)	11.9 (30.3)	—	53.4 (24.2)	19.0 (48.3)	19.0 (48.3)	—	105.2 (47.7)
300	11.9 (30.3)	12.2 (30.9)	380.4 (1439.9)	55.6 (25.3)	19.0 (48.3)	19.3 (48.9)	668.7 (2531.2)	107.4 (48.7)

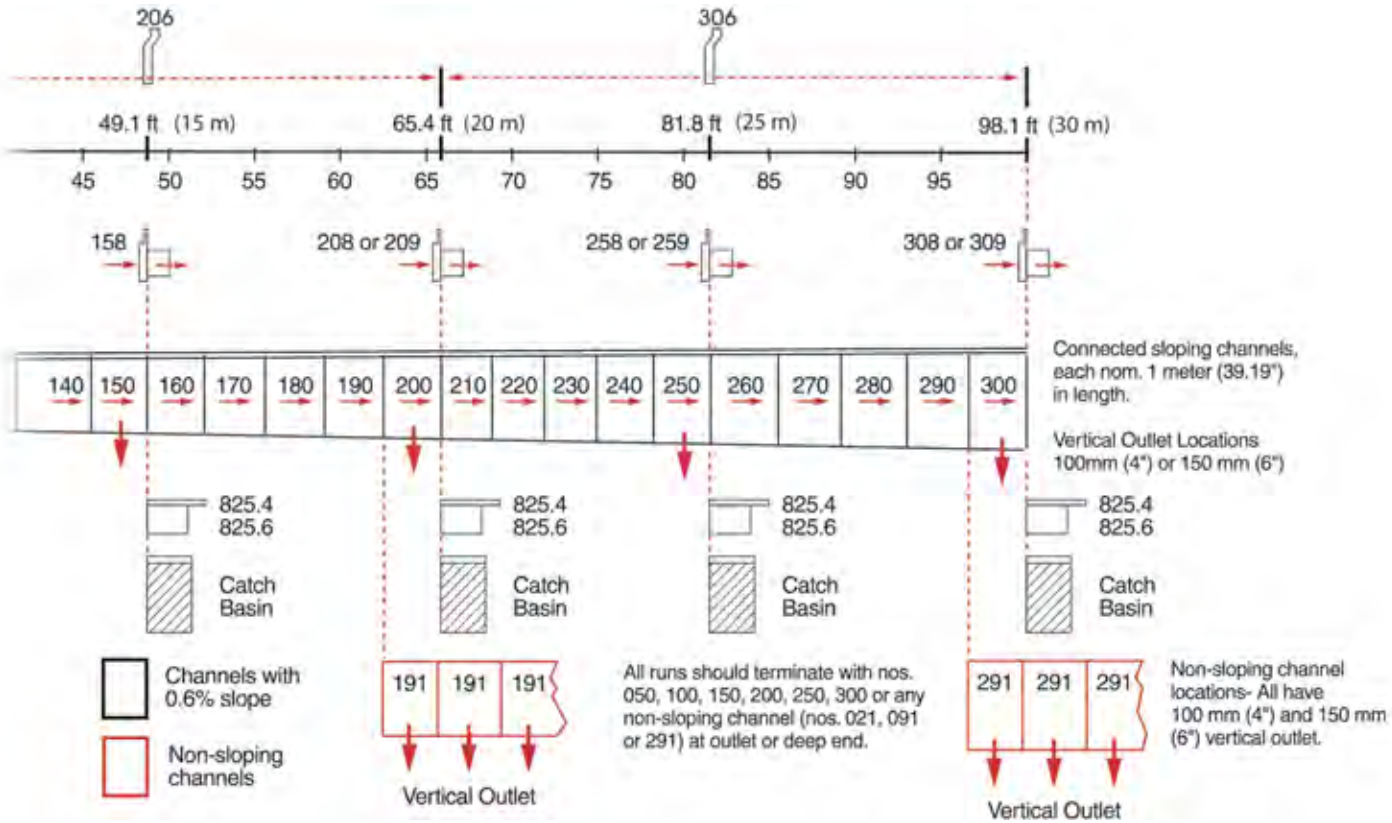

Channel With PolyWall II				Part No.
Overall Channel Depth in. (cm)		Maximum Flow Rate gpm (lpm)	Weight lbs (kg)	
Minimum	Maximum			
19.3 (48.9)	19.5 (49.5)	678.3 (2567.6)	106.5 (46.3)	010
19.5 (49.5)	19.7 (50.1)	687.9 (2604.1)	108.2 (47.1)	020
19.7 (50.1)	19.7 (50.1)	—	107.4 (46.7)	021
19.7 (50.1)	20.0 (50.7)	697.6 (2640.5)	109.0 (47.4)	030
20.0 (50.7)	20.2 (51.3)	707.2 (2677.0)	109.7 (47.7)	040
20.2 (51.3)	20.4 (51.9)	716.8 (2713.5)	109.2 (47.5)	050
20.4 (51.9)	20.7 (52.5)	726.5 (2750.0)	110.6 (48.2)	060
20.7 (52.5)	20.9 (53.1)	736.1 (2786.4)	111.6 (48.6)	070
20.9 (53.1)	21.1 (53.7)	745.7 (2822.9)	112.4 (49.0)	080
21.1 (53.7)	21.4 (54.3)	755.4 (2859.4)	113.4 (39.4)	090
21.4 (54.3)	21.4 (54.3)	—	112.8 (49.2)	091
21.4 (54.3)	21.4 (54.3)	—	95.5 (41.3)	096
21.4 (54.3)	21.6 (54.9)	765.0 (2895.9)	113.0 (49.3)	100
21.6 (54.9)	21.9 (55.5)	774.7 (2932.4)	115.2 (50.3)	110
21.9 (55.5)	22.1 (56.1)	784.3 (2968.9)	116.0 (50.6)	120
22.1 (56.1)	22.3 (56.7)	793.9 (3005.4)	117.8 (51.4)	130
22.3 (56.7)	22.6 (57.3)	803.6 (3041.9)	118.2 (51.6)	140
22.6 (57.3)	22.8 (57.9)	813.2 (3078.4)	118.0 (51.5)	150
22.8 (57.9)	23.0 (58.5)	822.9 (3114.9)	119.6 (52.3)	160
23.0 (58.5)	23.3 (59.1)	832.5 (3151.4)	120.5 (52.7)	170
23.3 (59.1)	23.5 (59.7)	842.1 (3187.9)	121.5 (53.1)	180
23.5 (59.7)	23.7 (60.3)	851.8 (3224.4)	122.2 (53.4)	190
23.7 (60.3)	23.7 (60.3)	—	122.0 (53.3)	191
23.7 (60.3)	24.0 (60.9)	861.4 (3260.9)	122.3 (53.5)	200
24.0 (60.9)	24.2 (61.5)	871.1 (3297.4)	124.0 (54.2)	210
24.2 (61.5)	24.4 (62.1)	880.7 (3333.9)	125.2 (54.8)	220
24.4 (62.2)	24.7 (62.7)	890.4 (3370.4)	125.4 (54.9)	230
24.7 (62.7)	24.9 (63.3)	900.0 (3406.9)	126.9 (55.6)	240
24.9 (63.3)	25.2 (63.9)	909.7 (3443.4)	125.9 (55.1)	250
25.2 (63.9)	25.4 (64.5)	919.3 (3480.0)	127.8 (55.9)	260
25.4 (64.5)	25.6 (65.1)	929.0 (3516.5)	128.4 (56.2)	270
25.6 (65.1)	25.9 (65.7)	938.6 (3553.0)	129.9 (56.9)	280
25.9 (65.7)	26.1 (66.3)	948.2 (3589.5)	130.3 (57.1)	290
26.1 (66.3)	26.1 (66.3)	—	128.8 (56.4)	291
26.1 (66.3)	26.3 (66.9)	957.9 (3626.0)	131.0 (57.4)	300

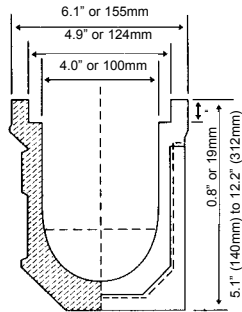

- Minimum overall depth (No. 010) 5.1 in. (128 mm)
- Maximum overall depth (No. 300) 12.2 in. (309 mm)
- Inside top width (all channels) 4.0 in. (100 mm)
- Maximum cross section flow area 39.9 sq. in. (25,400 mm²)
- Length of slope system 98.1 feet (30 m)
- Channel bottom thickness 1.0 in. (nom.) (20 mm)

PolyDrain systems can be extended to greater lengths by insertion of any number of non-slope channels (No. 021, 091, 096, 191, and 291) at the appropriate locations, or by the addition of PolyWall sidewall extensions.

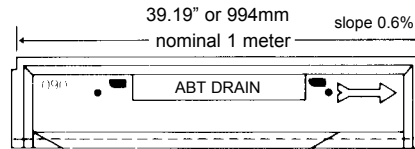

Run Variations

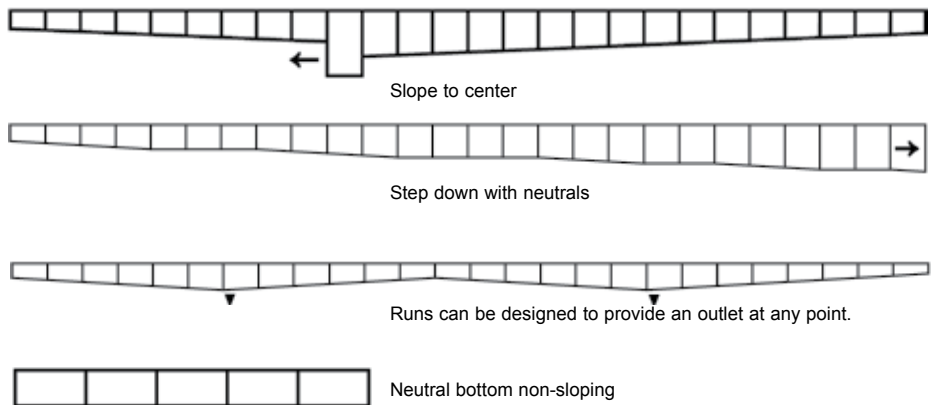

400 Series Stamped Grates

Solid Covers

Part No.	Material	Load Class	Length in (m)	Weight lbs	Locking Device
2404	Solid Cover, smooth	A	39.19 (1.0)	6	2810A
2406	Solid Cover, embossed	A	39.19 (1.0)	6	2810A
2444	18-8 Stainless steel, smooth	A	39.19 (1.0)	7	2840A
2446	18-8 Stainless steel, embossed	A	39.19 (1.0)	7	2840A

- above covers available in 1/2 meter lengths -



Solid Cover - Smooth

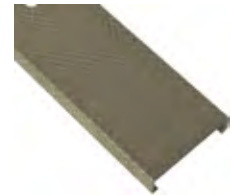

Solid Cover - Embossed

Perforated Heel-Proof Grates

Part No.	Material	Load Class	Length in (m)	Weight lbs	Locking Device
2410	Galvanized Perforated	A	39.19 (1.0)	6	2810A
2452	18-8 Stainless steel	A	39.19 (1.0)	6	2840A

- above covers available in 1/2 meter lengths -



Perforated - Heel Proof



Slotted

Reinforced Perforated Heel-Proof Grates

Part No.	Material	Load Class	Length in (m)	Weight lb	Locking Device
2412	Galvanized steel	C	39.19 (1.0)	8	2810A
2412.19	Galvanized steel, 19 stiffeners	D	39.19 (1.0)	10	2810A
2454	Stainless steel	C	39.19 (1.0)	8	2840A
2454.19	Stainless steel, 19 stiffeners	D	39.19 (1.0)	10	2840A
2486	Brass	B	39.19 (1.0)	8	2892A

- above covers available in 1/2 meter lengths -



720 -FRP



722 -FRP

Slotted Steel Grates

Part No.	Material	Load Class	Length in (m)	Weight lb	Locking Device
2420	Galvanized steel	B	39.19 (1.0)	6	2811A
2440	Stainless steel	B	39.19 (1.0)	6	2841A

- above covers available in 1/2 meter lengths -

Reinforced Slotted Steel Grates

Part No.	Material	Load Class	Length in (m)	Weight lb	Locking Device
2422	Galvanized steel	C	39.19 (1.0)	8	2811A
2422.19	Galvanized steel	D	39.19 (1.0)	8	2811A
2442	Stainless steel	C	39.19 (1.0)	8	2841A
2442.19	Stainless steel	D	39.19 (1.0)	8	2841A

- above covers available in 1/2 meter lengths -

2700 Series FiberGlass Grates (FRP)

Part No.	Material	Load Class	Length in (m)	Weight lb	Locking Device
2720	Vinylester FRP (bars on 1" centers)	B	39.19 (1.0)	4	2887
2722	Vinylester FRP (bars on 0.6" centers)	D	39.19 (1.0)	6	2887

Vinylester Grates available in 1/2 meter



Example: Reinforced Underside

Static Load Classification							
based on modified AASHTO M-306 for Trench Drains							
	Load Class	Load Class	Load Class	Load Class	Load Class	Load Class	Load Class
	A	B	C	D	E	F	G
Application	Light Duty Pedestrian Traffic	Medium Duty Sidewalks & Residential Parking	Heavy Duty Commercial	Extra Heavy Duty Roads and Highway	Extreme Heavy Duty Hard Tire Forklift, Heavy Vehicles	Airport Rated Municipal and Regional Airports	Airport Rated International Airports or Intermodal - Port Facilities
Application Proof Load (psi)	75psi	150psi	310psi	494psi	620psi	1235psi	2469psi
Typical Applicable Standard	Foot Traffic	Light Pneumatic Tire Traffic	A-A60005 Fed- eral Spec.	AASHTO M-306 H-20	AASHTO M-306 HS-25	Airport (100,000 lbs)	Airport (200,000 lbs)

500 Series Slotted Cast Grates



2501



2502



2503



2504



2511AF



2512AF



2513AF



2514AF



2532



2534

Ductile Iron Solid Cover

Part No.	Material	Load Class	Length in (m)	Weight lb	Locking Device
2501	Ductile iron	G	19.60 (0.5)	12	2811B

Slotted Grates

Part No.	Material	Load Class	Length in (m)	Weight lb	Locking Device
2502	Ductile iron	E	19.60 (0.5)	8	2811B
2503	Ductile iron	G	19.60 (0.5)	11	2811B

Longitudinally Slotted Grates

Part No.	Material	Load Class	Length in (m)	Weight lb	Locking Device
2504	Ductile iron	E	19.60 (0.5)	10	2811B

2510AF Ductile Iron Frame & Ductile Grate

Part No.	Material	Load Class	Length in (m)	Weight lb	Locking Device
2511AF	Ductile iron frame and 2501	G	19.60 (0.5)	21	2815B
2512AF	Ductile iron frame and 2502	E	19.60 (0.5)	15	2815B
2513AF	Ductile iron frame and 2503	G	19.60 (0.5)	18	2815B
2514AF	Ductile iron frame and 2504	E	19.60 (0.5)	17	2815B

2530 Frame & Grate Assemblies

Part No.	Material*	Load Class	Length in (m)	Weight lb	Locking Device
2532	Gray iron (class 30) frame and 2502 type grate	G	19.60 (0.5)	30	2815F
2534	Gray iron (class 30) frame, ductile iron longitudinally-slotted grate	G	19.60 (0.5)	25	2815F

2510 Ductile Iron Frames

Part No.	Material*	Length in (m)	Weight lb	Lockin Device
2510AF	Ductile Iron	19.60 (0.5)	9	N/A
2510MFFAF	Ductile iron	19.60 (0.5)	9	N/A

NOTE: One is required at each end run, one at each tee, two are required at 90° turn.

*All ductile iron grates and frames available with galvanized coating. All ductile and cast grates have compatible anchor frames.

Heavy Duty Stainless Steel Forklift System

Part No.	MaterialClass	Length in(m)	Weight lbs	Locking Device
2468.SSHD	S.S. Heavy Duty Frame & Grate	19.60 (0.5)	12	2877.SSHD

Note:

- Always use a frame when hard wheel traffic is anticipated.
- ABT recommends a frame or overlay rail if regular or frequent pneumatic traffic is expected.



2510AF Anchor Frame



2510MFFAF End Frame



2468.SSHD

Ornamental Grates Series

2336 Series Ornamental Thermoplastic Grates

Part No.	Material*	Load Class	Length in (m)	Weight lb	Locking Device
2336	Thermoplastic "Herringbone"	A	19.60 (0.5)	1.1	2840A.25A
Stock Colors: Black		Call for available colors			



2336 "Herringbone"



2506 Herringbone

2509 Series Ornamental Ductile Iron Grates

Part No.	Material*	Load Class	Length in (m)	Weight lb	Locking Device
2506	Ductile iron "Herringbone"	E	19.60 (0.5)	7	2810A
2509	Ductile iron "Imperial Star"	D	19.60 (0.5)	10	2810A
2509A	Ductile iron "Maze"	D	19.60 (0.5)	10	2810A
2509B	Ductile iron "River Wave"	D	19.60 (0.5)	10	2810A
2509C	Ductile iron "Incan Myth"	D	19.60 (0.5)	10	2810A
2509D	Ductile iron "Rain Drops"	D	19.60 (0.5)	10	2810A
2509E	Ductile iron "Fern"	D	19.60 (0.5)	10	2810A
2509F	Ductile iron "Picaso"	D	19.60 (0.5)	10	2810A
2509G	Ductile iron "Smooth Stones"	D	19.60 (0.5)	10	2810A



2509 "Imperial Star"



2509A "Maze"

2519 Series Anchor Frame & Ornamental Grate Assemblies

Part No.	Material	Load Class	Length in (m)	Weight lb	Locking Device
2516	Ductile iron frame and 2506	E	19.60 (0.5)	16	2810AXL
2519	D.I. Frame and 2509 "Imperial Star"	D	19.60 (0.5)	19	2810AXL
2519A	D.I. Frame and 2509A "Maze"	D	19.60 (0.5)	19	2810AXL
2519B	D.I. Frame and 2509B "River Wave"	D	19.60 (0.5)	19	2810AXL
2519C	D.I. Frame and 2509C "Incan Myth"	D	19.60 (0.5)	19	2810AXL
2519D	D.I. Frame and 2509D "Rain Drops"	D	19.60 (0.5)	19	2810AXL
2519E	D.I. Frame and 2509E "Fern"	D	19.60 (0.5)	19	2810AXL
2519F	D.I. Frame and 2509F "Picaso"	D	19.60 (0.5)	19	2810AXL
2519G	D.I. Frame and 2509G "Smooth Stones"	D	19.60 (0.5)	19-	2810AXL



2509B "RiverWave"



2509C "Incan Myth"

2510 Series Ductile Iron Anchor Frames

Part No.	Material*	Length in (m)	Weight lb	Lockin Device
2510AF	Ductile Iron	19.60 (0.5)	9	N/A
2510MFFAF	Ductile Iron	19.60 (0.5)	9	N/A

NOTE: One is required at each end run, one at each tee, two are required at 90° turn.

*All ductile iron grates and frames available Raw, Epoxy Coated, and Galvanized. All ductile and cast grates have compatible anchor frames.

Locking Devices

Grate locking devices are recommended for all applications involving vehicular traffic, or where vandalism may be a problem. Locking devices are provided in zinc-plated, stainless steel and brass. The bolt is threaded into the lock toggle through the hole provided in the grate prior to grate installation. As the bolt is tightened, the toggle cams into place for hands-free installation.

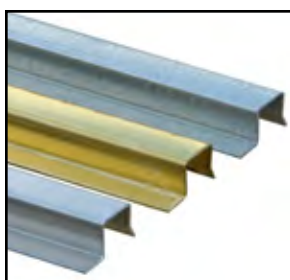

Overlay Rails

Overlay Rails are made of galvanized steel, stainless steel or brass and are applied to any standard channels. They cover and protect the channel edge in medium-duty traffic applications. When visual aesthetics are important, the Overlay Rails enhance the appearance of the PolyDrain channels.

(Overlay rails for end plates are available).



2509D "Rain Drops"



2509E "Fern"



2509F "Picaso"



2509G "Smooth Stone"

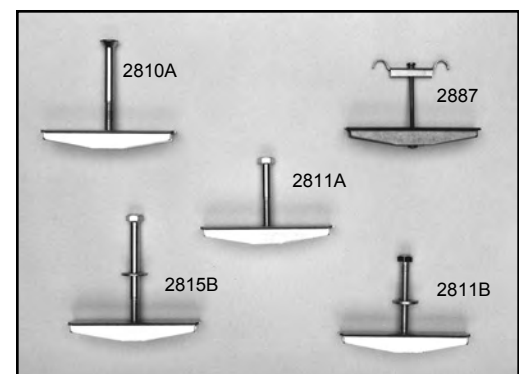

PolyWall® Sidewall Extensions

PolyWall I and II Sidewall Extensions allow the designer or contractor to extend a continuous-sloping channel run from 98.1 ft. (30 m) to 294.3 ft. (90 m) without necessity of a catch basin or outlet.

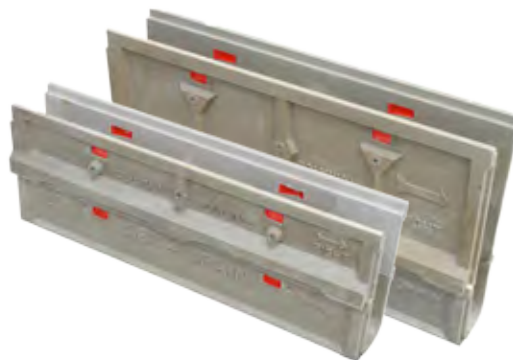

Gender Mender Outlet Channel

A series of specially modified channels that addresses the difficulties encountered when two sloping channels converge where a vertical outlet is required. For every outlet channel (050, 100, 150, 200, 250 and 300), a Gender Mender channel is molded with a female interlocking joint at the low point. This feature provides proper channel alignment and eliminates field fabrication for these center draining configurations.

2900 Series Small Catch Basins

PolyDrain's 2900 Series Catch Basins have the same outside dimensions as standard PolyDrain channels. Designed to accept sidewall extensions, they can be positioned any place in a channel run. The 2900 Series Catch Basins are available with easy-to-remove stainless or galvanized steel trash buckets and can accept the full range of lockable inlay or frame-and-grate systems. Available with foul air traps when required.



2610-2611 Large Catch Basins

PolyDrain's 2610 and 2611 Large Catch Basins are designed to accept large volumes of fluids. Removable stainless or galvanized steel trash buckets are available and a cast iron grate and frame is included. Catch basins are 19.6" long and 12.8" wide and have pre-formed cutouts for insertion of channels and 6 in. (150 mm) outlets on all four sides of the basin, although other pipe sizes can be fitted to the catch basin as required. PolyDrain Large Catch Basins have a stackable design which allows for installation to any required depth.

2600 Series Grates

Grates for 2600 Series Catch Basins

Part No.	Material	Load Class	Length in (m)
2604	Slotted Ductile iron	E	18.87 (0.48)
2616	Solid Cover- Steel	D	18.87 (0.48)
2616.506	Heelproof Herringbone	C	18.87 (0.48)
2616.504	Longitudinal Slotted	C	18.87 (0.48)
2604.SSHD	Stainless Steel	D	18.87 (0.48)
2604.FRP	Fiberglass	B	18.87 (0.48)

Inlets, Outlets, and End Caps

All 4 in. (100 mm) horizontal plates have inlet or outlet capability. As outlets, they fit the downstream end of every fifth channel, or as inlets, the upstream end of the following channel. All 4 in. (100 mm) plates are made with a PVC sleeve to accept either SCH40 or SDR35 pipe. 6 in. (150 mm) outlet plates are made with a special adapter flume. Vertical outlet plates fit over the cut-outs on each of the outlet channels. 8 in. and 12 in. outlets are also available.



Grate Cover Tape

Grate Cover Tape is ideal for keeping the grates clean during installation. Available in 200ft rolls..

Shovel Head

Designed to conform to the PolyDrain channel bottom. For inlay grate systems only.

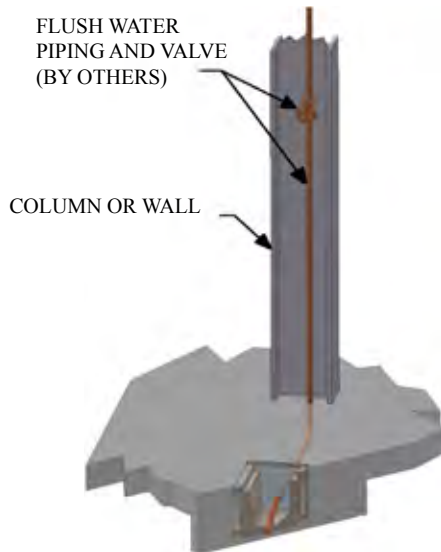

PolyJet

The PolyJet kit is an easy way to maintain trench drain systems by adding a flush water connection to the end of the trench drain run.

PolyJet kits are now available consisting of an end plate, stub pipe, retainer ring, and pipe connectors.

The PJ306 Kit is compatible with all size PolyDrain channels. The 306 end cap fits the deepest channel but the pipe hole is located for the shallowest depth channel. A $\text{Ø } \frac{1}{2}$ " by 6" long soft copper pipe fits through the hole in the end cap and provides means to direct the flow stream for best cleaning with minimal splash. A retainer ring secures the copper pipe in place during concrete placement. Included connections are $\text{Ø } \frac{1}{2}$ " NPT male, $\text{Ø } \frac{1}{2}$ " NPT female, and $\text{Ø } \frac{1}{2}$ " solder coupling. Remove any excess end cap length if it causes complications during installation.

PolySeal

PolySeal 1 is a single-part polyurethane in a standard paper caulk tube, and is used as a general purpose sealant for gray water applications.

PolySeal 2 is a two-part epoxy in a double tube with a static mixing nozzle. PolySeal 2 maintains a permanent flexibility and offers chemical resistant properties.

PolySeal 3 is a two-part vinyl ester sealant which sets hard in about 30 minutes. It is recommended for sealing all joints in a PolyChampion installation. It is also ideal for bonding all PolyDrain fabrications and mitres.



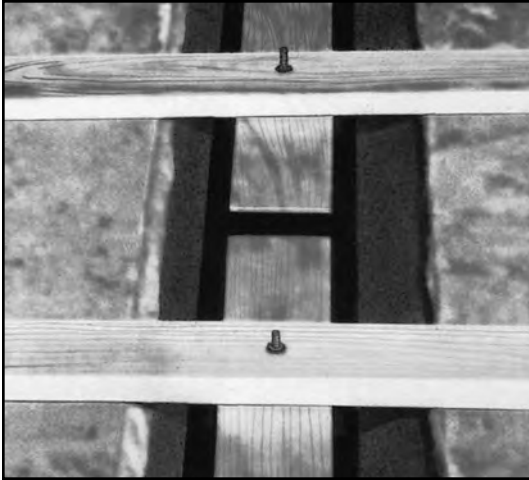

Suspended Installation

This method is best suited for retrofit installations. The existing slab serves to suspend channel sections, or in a new construction using forming boards for the same purpose.

Using 2" x 4" boards of sufficient length to span the trench, and 6" long threaded bolts or all thread bolts with toggle bars, secure channels to the boards.

With channels properly positioned, place and consolidate concrete under and around the channels, then finish to the proper grade.

PolyClip I Installation Aids

PolyClip™ was developed to speed channel installation and make the joining of the channels more secure before the pour. PolyClip consists of: two special securing brackets (one for either side of the channel); a “no-float” U-shaped leg that serves to maintain proper height and keep channels from floating during the pour; and a securing bolt to keep the entire appliance attached to the channel.

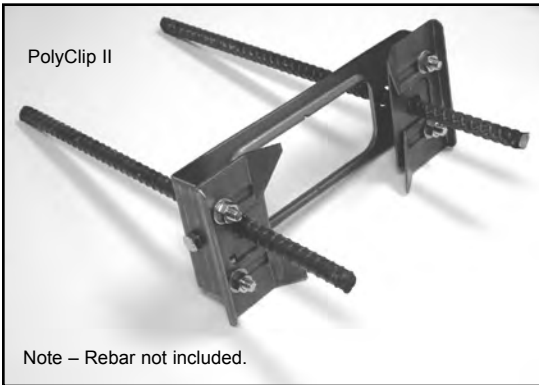
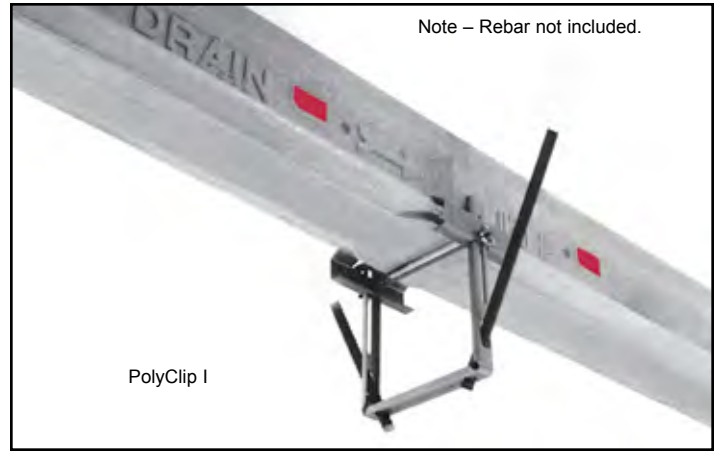

PolyClip II Installation

PolyClips are installed at the channel joints. Height adjustment is made by loosening the clamp bolt and sliding base brackets up or down on the rebar legs. Lateral and longitudinal adjustment plus retention are made by positioning and tightening adjustment clips on the top of the installation device.

Other quality products by ABT, Inc.



Available for download on our website
www.abtdrains.com

Suggested Specification (Short Form)

Section 02725 — Precast Trench Drain and Catch Basin System

Part 2 — Products

A. Acceptable manufacturers:

1. Surface drain system:
 - a. Base: PolyDrain; manufactured by ABT, Inc., PO Box 837, 259 Murdock Rd., Troutman, NC 28166; 1-800-438-6057.

B. Components:

1. Drain trench: Fabricated of polyester polymer concrete, 6.1 in. (155 mm) wide, 4 in. (100 mm) ID with radiused bottom, having following attributes:
 - a. Lengths: 19.6 in. (Nominal 0.5 meter) and 39.19 in. (1.0 meter).
 - b. Bottoms: Sloped to provide 0.6% slope.
 - c. Anchoring ribs: Full length.
 - d. Grate locking slots: Blind, vibration damping, thermoplastic.
 - e. Interlocking ends.
 - f. Available to 294 ft. (90 m), continuous slope using sidewall extensions.

Specifier: If corrosive products will be transported with this system, change polyester to vinylester and add compatible sealant. See the PolyDrain Chemical Resistance Guide for suitable material specification information.

2. Grates:

- a. Perforated heel-proof, steel.
- b. Slotted steel.
- c. Ductile iron anchor frames.
- d. Grey iron anchor frames.
- e. Fiberglass.
- f. Engineering grade thermoplastic.

3. Accessories:

- a. End plates.
- b. Outlet plates.
- c. Strainer.
- d. Locking devices.
- e. Sealant.
- f. Polywall sidewall extensions.
- g. Installation devices.
- h. Catch basins.

Specifier: Select grate type from catalog and enter part number. Assure that selected type meets loading requirements. Select proper accessories, insert model numbers. Always use cast anchor frames for hard tire loadings. Delete items not used.

Part 3 — Execution

3.02 Preparation

- A. Where sealant is required, roughen surface, and acetone wash area to receive sealant.

Cross-Sectional View Channel with In-lay Type Grate

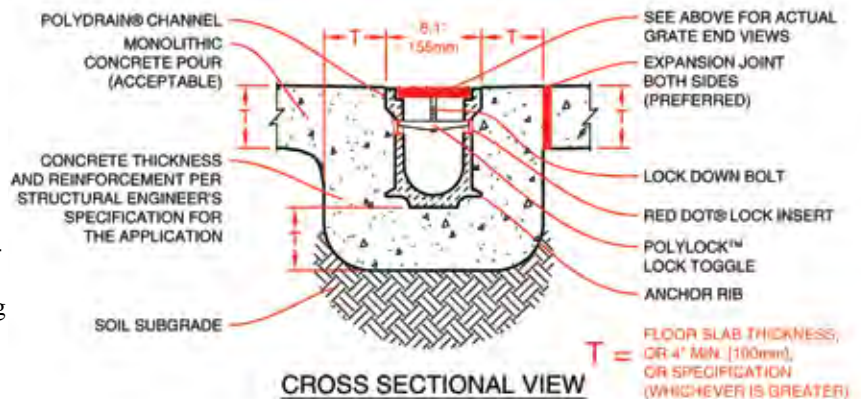

The encapsulation concrete shall be placed on both sides and under the channels. The strength, thickness, and reinforcement should be that recommended by the customer's structural engineer for the intended application.

Cross-Sectional View Channel with Frame and Grate

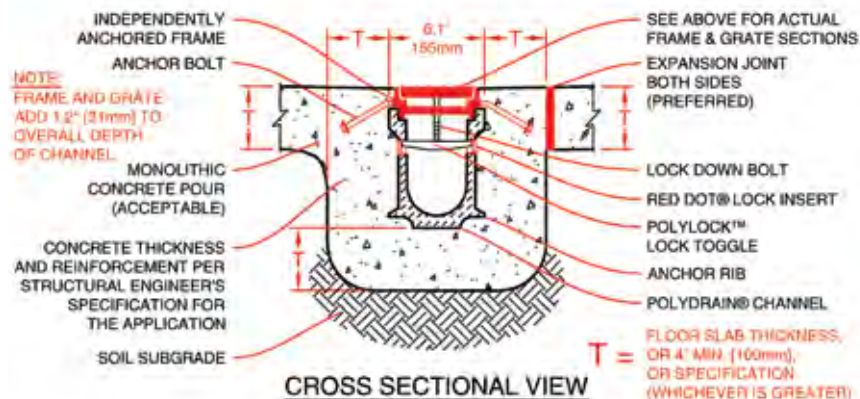

The encapsulation concrete shall be placed on both sides and under the channels. The strength, thickness, and reinforcement should be that recommended by the customer's structural engineer for the intended application.

3.03 Installation

- A. In accord with manufacturer's instructions.
- B. Utilize manufacturer's approved installation device to assure proper joints, drawn tightly together by device.
- C. The trench excavation must allow for the placement of the concrete on both sides and the bottom of the channel(s) for the thickness and reinforcement specified by the designer or structural engineer.
- D. The trench drain and its encapsulating concrete should be isolated from the expansion and contraction stress of the adjacent slabs.

For comprehensive long-form specifications and details in print or digital format visit our website at

www.abtdrains.com

ABT, INC.

PO Box 837 ■ 259 Murdock Road ■ Troutman, NC 28166 ■ TEL 704-528-9806 ■ FAX 704-528-5478
Toll Free 800-438-6057 ■ Email: sales@abtdrains.com ■ ©ABT, Inc. Printed in the U.S.A. 5/10