

# Trench Former®

# Oil Water Separator

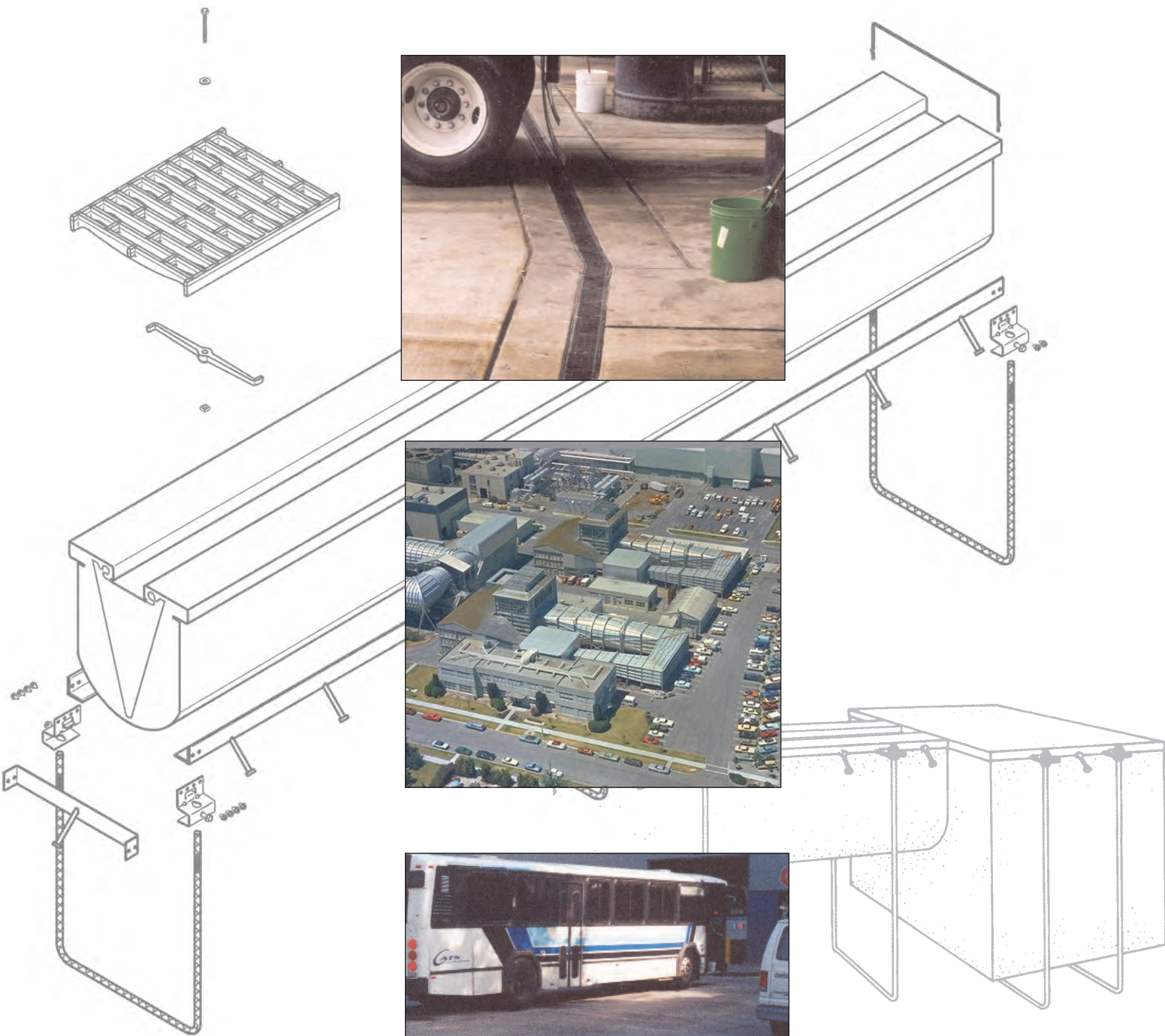

**ABT, INC.**  
Advanced Building Technologies, Inc.

[www.abtdrains.com](http://www.abtdrains.com)



## Trench Former<sup>®</sup> Oil Water Separator

The **Oil Water Separator**, by ABT,<sup>®</sup> Inc., manufacturer of Polydrain,<sup>®</sup> is a valuable and timely addition to our product line. As environmental regulations become more stringent, separators have become a must in facilities where oil and grease are present in the drainage stream and pose a threat as a pollutant. This unique product provides static separation of solid debris, free oils or other non-soluble chemicals from drain water before discharge.

Unlike other separators, the Oil Water Separator is a light-weight, easily installed forming system. Using patented, non-floating formwork, the Oil Water Separator installs without the necessity of heavy equipment. It provides a cost-effective system of unequalled efficiency.

The Oil Water Separator is the natural choice for high-performance requirements, such as:

- Bus barns
- Auto repair facilities
- Parking areas
- Gasoline stations
- Chemical transfer stations
- Airports
- Landfills
- Oil storage areas
- Refueling depots

.... anywhere petroleum contaminants must be isolated and removed.

### Product Description

The natural force of gravity separates oil, water and solid particles in the waste stream. Free oil droplets, being lighter than water, rise to the surface of the filled tank while heavier solids settle to the bottom. A baffle is used to prevent the waste stream from circumventing the system during heavy flow conditions. It also retains solids in the inlet chamber, away from the discharge opening. A pipe tee at the top of the stand pipe assembly serves as a vacuum break and as a means of examining the discharge stream. The basic system contains no moving parts. Periodic removal of captured oil and solids is the only maintenance required.

The frame rails and "no-float" legs are quickly fastened together with nuts and clips to form a lightweight, yet sturdy, assembly.

Reinforced diamond plate steel covers are designed for pedestrian or H-20 heavy-duty loading applications. All covers include retainers for security and safety. The complete Oil Water Separator assembly includes all piping and fittings.

A pre-cut, expanded polystyrene (EPS) form is used to create the correctly-shaped cast-in-place concrete tank. Cutouts in the form locate inlet and outlet pipe positions and form a slot for the insertable overflow baffle.

The Oil Water Separator form is positioned and restrained from flotation by a 1 3/4" x 1 3/4" x 3/16" structural steel angle frame with welded anchor studs and "no-float" leg brackets attached.

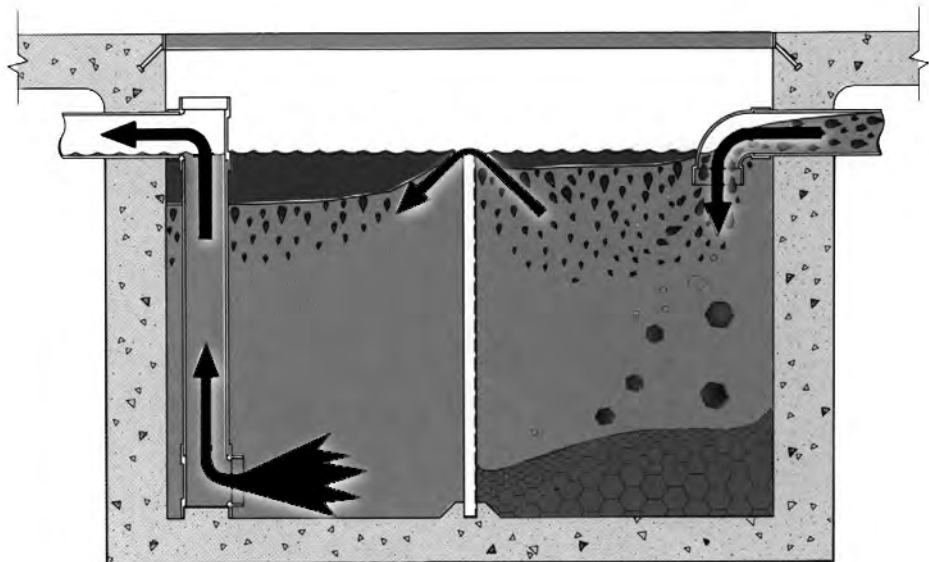

## Standard Features

- Three storage capacities — 160, 240, and 320 gallon.
- Three flow capacities — 21, 31 and 42 gallons per minute.
- Full perimeter steel anchor frame
- Patented no-float installation legs
- Internal PVC piping and fittings
- Preformed deforming grooves
- Full width overflow weir to maintain laminar fluid flow
- Ability to inspect discharge stream



## System Specifications

Part Number	Storage Capacity	API Design Capacity	Dimensions (wxhxd)	I/O Invert	Installation Wt w/o Cover	Shipping Weight
	gal (ltr)	gpm (lpm)	in.	in. (mm)	lbs (kg)	lbs (kg)
S160	160 (600)	21 (79)	23x48x48	12 (305)	75 (34)	235 (107)
S240	240 (900)	31 (119)	23x48x72	12 (305)	115 (52)	310 (141)
S320	320 (1200)	41 (158)	23x48x96	12 (305)	150 (68)	390 (177)

**Suggested Specification:** Please refer to the Specification Writer on the ABT Inc. website: [www.abtdrains.com](http://www.abtdrains.com)

## Custom Separators

Some separation requirements extend beyond the capabilities of the standard Trench Former Oil Water Separator. We can provide a number of options to accommodate specific needs. The following modifications and accessories are available on a custom basis:

- 25 mil reinforced geomembrane containment barrier
- Special capacities and dimensions
- Internal oil storage
- Multiple and diffuser baffles
- Second liner allowing for additional leak detection



The information contained within is believed to be accurate but not guaranteed to be so. The customer should evaluate the suitability and safety of these products for any application. ABT assumes no liability for the end results since the conditions of installation and use are beyond the control of ABT. Concrete specifications, placement, reinforcement and structural considerations are the responsibility of the customer. ABT reserves the right to change the price, availability, specifications, and content of any of its products, literature or other information in all media at any time without notification.

## Installation

1. Excavate a pit which is 60" deep, 38" wide, and 14" longer (62", 86" or 110" long) than the length of unit being installed. Careful excavation will eliminate need for additional "doghouse" form work.

2. Remove EPS form from protective billet. Feed 16 gauge tie wire through holes at top of all deform grooves. The deform wire is used to complete the cut through EPS form after concrete sets to ease foam removal. Saw grooves through flange in side of EPS form so that deform wires are inside rails. Store wire ends in top surface of form. (See Figure 1)

**Figure 1**

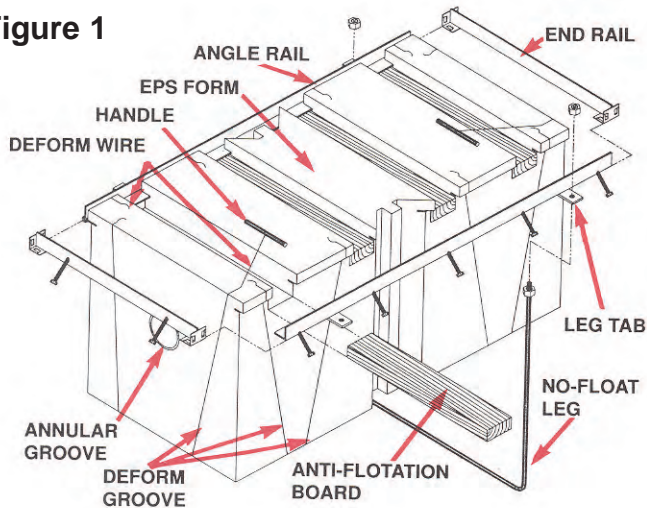

3. Install 21 1/4" long 2 x 4's in each slot on top of EPS form. Orient angle rails so that leg tabs are horizontal and place angle rails into longitudinal groove near top of form. The 2 x 4 anti-flotation boards must be below angle rails and flush with sides of EPS form. Clip on end rails to secure angle rails.

4. Run one nut to end of threads on each no-float leg threaded end. Place no-float leg into holes in leg tabs. Secure tightly with second nut. The form assembly is now complete.

5. Install form assembly in trench with correct orientation (round pocket on bottom of EPS form at discharge end), position, and elevation. Secure to suspending lumber by looping and tightening tie wire around anchoring studs on angle frame and suspending lumber. Top of rail should be level with finished grade. No-float legs should be suspended just above the floor of excavation.

6. Concrete is poured wall to wall in the excavation deep enough to cover no-float legs with a minimum of two inches of concrete to form the anchor slab. Let set hard and remove suspending lumber. (See Figure 2)

**Figure 2**

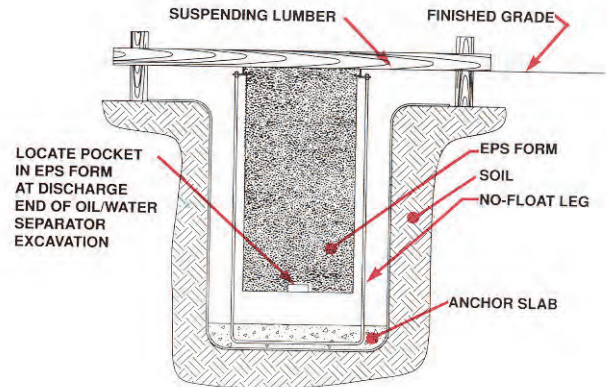

7. Insert inlet and outlet pipes firmly into factory cut annular grooves on ends of EPS form until they bottom in grooves. If pipe stubs are used, be sure stubs extend beyond the thickness of concrete tank wall. Back fill or support pipes in pipe trenches at the edge of the tank pit to prevent damage to EPS form during concrete pour.

8. Monopour concrete floor and walls around form. Finish concrete and let set for 24 hours.

9. Cut and remove anti-flotation boards from slots. Tie end of deform wires to scraps of rebar or similar material. Pull all wires until foam is completely severed. Then, lift out center section of EPS form with a shovel or pry bar. Remove all remaining EPS form pieces and discard. Take care not to damage ends of pipe inside of pit. (See Figure 3)

10. Assemble and install stand pipe assembly onto receptacle at the bottom of the outlet end and bond to outlet pipe. Bond elbow onto inlet pipe. Slide overflow baffle into grooves at sides of separator. Install and lock covers.

**Figure 3**

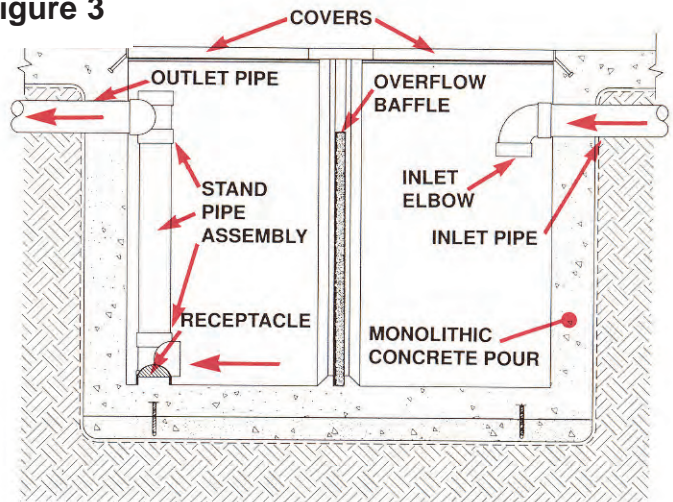

# ABT, INC.